

**DS1003**

**MUS2 Disc Brake Caliper - Spring applied Pneumatically released**

Nominal diamensions given  
For caliper dimensions see DS1000

Air Inlet Port  
Rp1/4 (1/4" BSP)

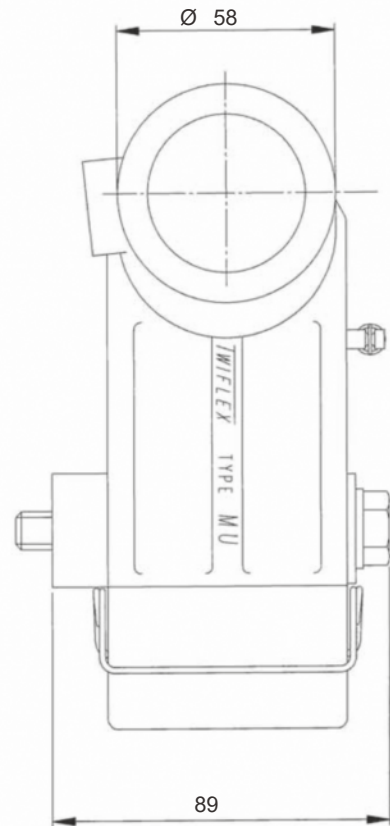
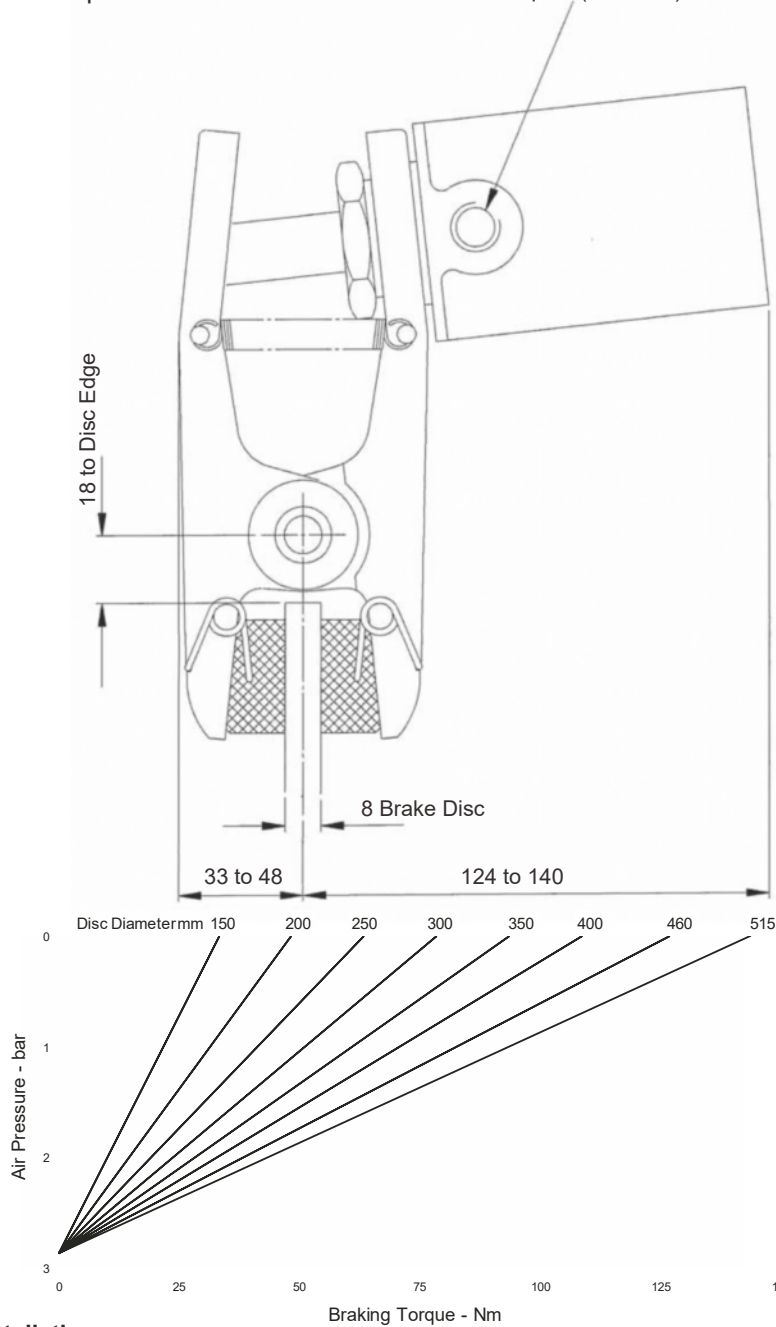

Weight (caliper and thruster) - 1.36kg  
(thruster only) - 0.61kg  
Minimum pressure for full retraction 4.3 bar

**Maximum Braking Force = 600N**

**Installation:**

Thrusters should be attached to the Caliper arm using the spacers and nuts provided. The maximum tightening torque is 60 Nm (44 lbf-ft). If possible the calipers should be operated using dry, filtered and non-lubricated air.

The ratings shown on the above graph are based on fully bedded and conditioned brake pads with nominal friction coefficient  $\mu = 0.4$ .

For bedding-in and conditioning procedures see Publication M1060.

Braking Force is defined as the Tangential Force acting on the brake disc at the Effective Disc Radius.

Braking Torque (Nm) = Braking Force (N) x Effective Disc Radius (m) where Effective Disc Radius = Actual Disc Radius - 0.02.

Twiflex Disc Brakes must be used with Twiflex asbestos free brake pads. The use of any other brake pads will invalidate the warranty. Twiflex reserves the right to modify or change the design without prior notice.



This approval is in Accordance with  
Certificate number 850822  
Issue 04 June 2009 © Twiflex 2001 Issue 05

Tel: +44 (0)1453 750814  
Fax: +44 (0)1453 765320  
www.howdon.co.uk  
sales@howdon.co.uk