

DB4603

GMR-S and GMR40-S Disc Brake Caliper - Spring Applied, Air Released

Nominal dimensions given.

For specific dimensions please contact us.

For GMR Mk 2 caliper details see DB 3604

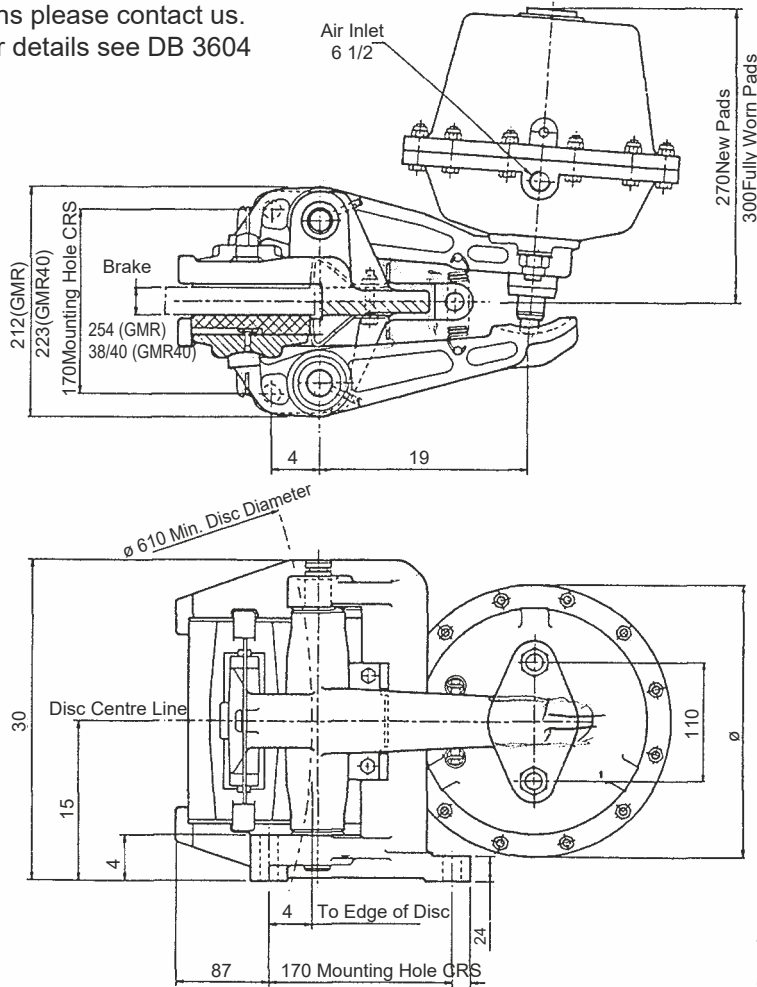

Note:
The caliper may be assembled as drawn (right hand assembly) or with arms and thruster oppositely handed.

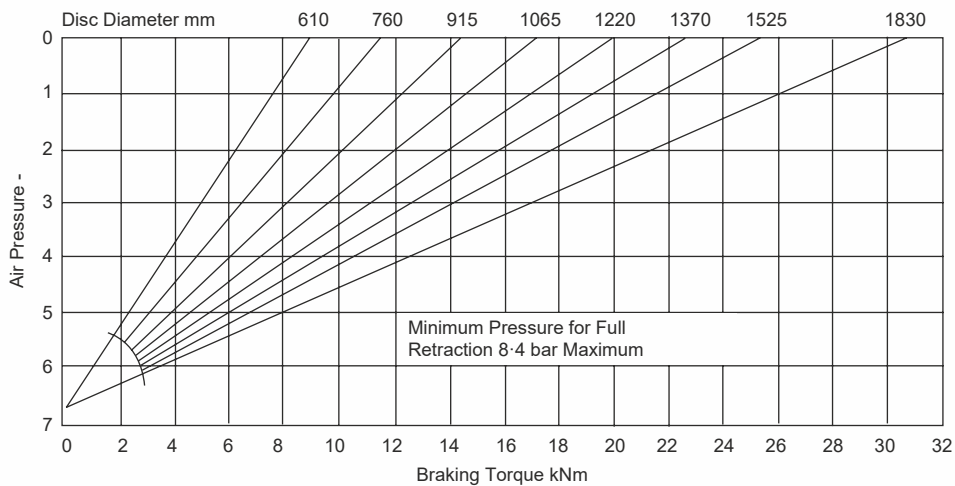

The ratings shown on the above graph are based on fully bedded and conditioned brake pads. For bedding in and conditioning procedures see Publication M1060.

Braking Force is defined as the Tangential Force acting on the brake disc at the Effective Disc Radius. Braking Torque (Nm) = Braking Force (N) x Effective Disc Radius (m)

where Effective Disc Radius = Actual Disc Radius - 0.06

GMR-S and GMR40-S Disc Brake Caliper - Spring Applied, Air Released

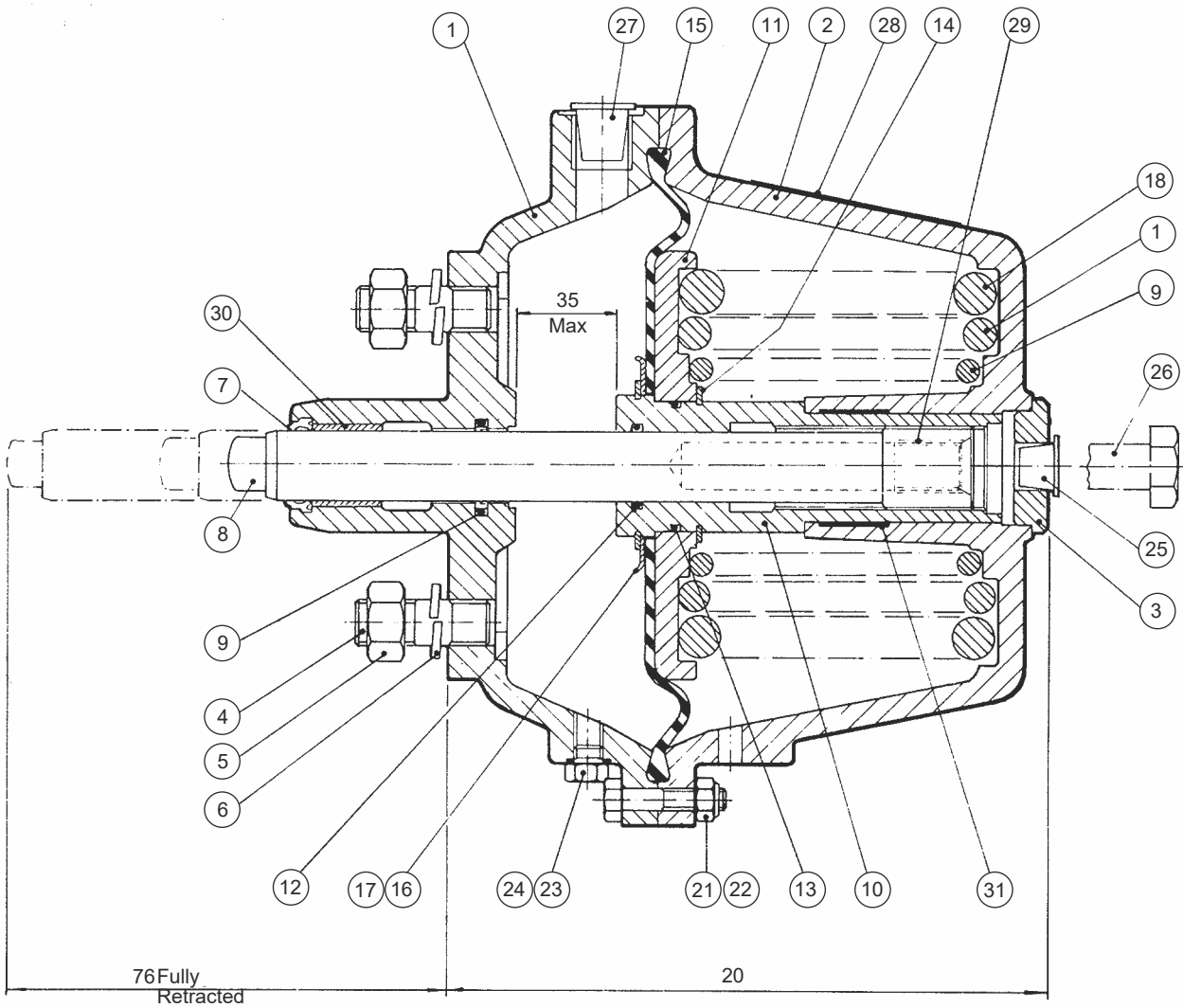

Thruster Type - S

Maximum Displacement Volume 1.3 l.

Parts List

Item	Description	Part No.	QTY
1	Front Cap	-	1
2	Rear Cap	-	1
3	Thrust Collar	-	1
4	Stud	-	1
5	M16 Nut	-	2
6	M16 Spring Washer	-	2
7	Wiper Seal	6000242	1
8	Pushrod	-	1
9	Rod Seal	6000243	1
10	Sleeve	-	1
11	Spring Plate	-	1
12	O' Ring	6000138	1
13	O' Ring	6000224	1
14	Circlip	-	1
15	Diaphragm	7200776	1
16	Support Plate	-	1

Item	Description	Part No.	QTY
17	Spring Ring	-	1
18	Main Spring	-	1
19	Centre Spring	-	1
20	Inner Spring	-	1
21	M8x 35 Bolt	-	12
22	M8 Nut	-	12
23	G 1/8 Plug	-	1
24	G 1/8 Washer	-	1
25	Redcap	-	1
26	Retraction Screw	-	1
27	G 1/2 Redcap	-	1
28	Label	-	1
29	Helicoil Insert	-	1
30	Bush	1800372	1
31	Bush	1800374	1

GMR-S and GMR40-S Disc Brake Caliper - Spring Applied, Air Released

The GMR-S and GMR40--S calipers are available in various ratings, as shown on the performance charts.

Part numbers are given below.

These are typical performance figures for bedded and conditioned brake pads having a friction coefficient of 0.4 when used with standard Twiflex discs an appropriate 'service factor' should be applied when designing the braking system and in the case of brakes used for holding duties or in wet conditions this should be not less than 2.0.

Marinised versions of the calipers, and thrusters with nodular cast iron castings (instead of aluminium alloy) are available to special order.

A monitoring unit is also available (Part No. 7700212) which is fitted to the back of the thruster. The unit incorporates two microswitches, of which one indicates full retraction of the pushrod (i.e. brake off) and the other indicates the need for adjustment due to pad wear.

Thruster Type	Thruster Part No.	Thruster Weight Kg	Max. Braking Force Kn	Retraction Oil Pressure Bar	Caliper Part No.	
					GMR	GMR 40
S 8.4	7200777	12.2	19.5	4.8	6780971	6781006
S 11	7200807	13.2	25	9.2	6780971	6781006
S 12.9	7200806	14	30	7	6780971	6781006
S 15.6	7200805	15	36	8.4	6780971	6781006

Installation, Operation and Maintenance

1. Installation

- 1.1 The caliper must be mounted on a suitably rigid support, upon which braking forces of up to 36kN will be imposed.
- 1.2 The caliper should be positioned symmetrically with respect to the disc, as shown on the drawing.
- 1.3 Three fixing bolts are required, M16 grade 8.8. The bolts should be tightened to a torque of 150Nm.
- 1.4 If the caliper is to be mounted on an inclined surface, the caliper should be fitted with adjustable stop screw and bias springs, included in the inclined mounting kit (Part Number 6700458, drawing number A11074).
- 1.5 Calipers are normally supplied assembled 'right-handed', as shown on the drawing, unless otherwise specified.
- 1.6 The thruster is normally supplied separately from the caliper, and with the retraction screw fitted to hold it in the 'off' position (see section 2.2) until it has been fitted on the caliper arm. Nuts and washers for this purpose are supplied and should be tightened to 45Nm torque. Thrusters are normally fitted with the air inlet uppermost.
- 1.7 The air inlet connection on the thruster is tapped G 1/2 (1/2" BSP). The air supply should be connected via a length of flexible tubing to accommodate the movement during operation. A quick exhaust valve may be fitted if very rapid brake operation is required.
- 1.8 Control of brake operation is effected by a 3 port, 2 position valve with open exhaust. Standard 'Twiflex' controllers, with electrical, pneumatic or hydraulic signalling are available if required.
- 1.9 The air supply used should be dry and oil free if possible; operation of the thruster at full stroke requires approximately 1.3 litres of compressed air.

2. Operation

- 2.1 The brake is applied by the thruster springs and released pneumatically. The required supply pressure varies with the caliper rating and is given on the performance charts. Variable braking torque can be achieved by regulating the air pressure as shown on the charts.
- 2.2 To enable the brake to be released in the event of air supply failure, a retraction screw is supplied (M16 x 130, Part number 5350249). This is inserted into the rear of the thruster and screws directly into the end of the pushrod; adequate access to the back of the thruster is required. The retraction screw is also used as the safety screw during maintenance.
- 2.3 THE RETRACTION SCREW SHOULD BE REMOVED COMPLETELY WHEN THE BRAKE IS IN SERVICE, and the red plastic cap supplied fitted in the hole. (The brake should be off i.e. pressurised, when removing the retraction screw).
- 2.4 THE THRUSTER STROKE SHOULD BE MAINTAINED AT ABOUT 20mm BY UNSCREWING THE PUSHROD. To adjust, the brake must be off (i.e. air pressure on). Pull the caliper arm away from the pushrod and turn the rod as required; one turn gives 2mm adjustment. Release the caliper arm, ensuring that the flats on the push rod are engaged in the slot in the caliper arm. (A 17mm A/F spanner will fit the flats on the pushrod).

GMR-S and GMR40-S Disc Brake Caliper - Spring Applied, Air Released

N.B. Keep fingers clear of the space between push rod and caliper arm at all times.
If an inclined mounting kit is fitted, the stop screw should be re-adjusted to maintain equal pad clearance on either side of the disc.

- 2.5 Pad wear can be monitored by observing the gap between the lugs on the pads pressure plates and the machined surfaces on the caliper frame, when the brake is applied. Pads must be replaced (see 3.2) before the gap is reduced to zero. The maximum allowable wear on a pad is 10mm).

3. Maintenance

CALIPER

- 3.1 Ensure that the brake pad and disc remain free from oil and grease. Clean the disc as require. If the pads become contaminated they should be replaced. Carry out any periodic statutory testing that is required, or otherwise check for satisfactory performance.
- 3.2 Pad replacement is carried out from the rear of the caliper; DO NOT release the spring clips which attach the pressure plates to the caliper arms. With the brake off (retraction screw may be fitted as a safety screw) remove the caliper return springs and the keep plates. If an inclined mounting kit is fitted, remove this also. Withdraw the pads to the rear and lift out. (The hole in the end of the pad retaining plates is provided to assist in withdrawing the pads). Fit the new pads (part number 7080080), ensuring that the slotted retaining plate is located around the keep disc on the pressure plate; the pads should slide freely into position. Replace remaining parts. Re-adjust the push rod, as in (2.4), and the stop screw if fitted.
- 3.3 The surface of the caliper arm on which the thruster pushrod bears should be kept well greased. The knuckle joints between the caliper arms and the pressure plates should be cleaned occasionally, and a small amount of grease applied; the joints may be levered apart slightly against the pressure of the spring clip. Occasionally, or if caliper is not operating freely, inject a small amount of grease via grease nipples to lubricate the pivot pins, then rotate pins to distribute the grease. Any grease exuding past the O-rings should be wiped off. The pins may be turned by gripping the knurled end at the top of the caliper.

After extended one million operations or three years) use, the pivot pins should be withdrawn, cleaned, replaced and re-greased, or replaced if badly worn.

In order not to damage the O-ring seals on the pins, use the following procedure. Remove the top circlip, push pin down until the lower circlip and O-ring can be removed, then withdraw the pin upwards. To refit, reverse this procedure.

THRUSTER

- 3.4 Clean the push rod as required. If the air supply is wet, the drain plug (23) should be removed at intervals to release any accumulated water.

In the event of leakage or malfunction of the thruster, the following parts can be inspected and replaced if necessary, using the procedures described below, without decompressing the spring pack:-

- Diaphragm (15)
- Rod Seal (9)
- Bush (30)
- Wiper Seal (7)
- Push rod (8)

- 3.5 Replacement of any other component, i.e. O-rings (12), (13), bush (31) and springs requires the spring pack to be decompressed. This is not covered in these instructions, and should only be carried out by Twiflex or their agents. If the pushrod is known to be damaged, replace it first, as in 3.11. Otherwise proceed as below.

WARNING:- DO NOT ATTEMPT TO DECOMPRESS THE SPRINGS BY UNSCREWING THE RETRACTION SCREW.

Thruster Servicing

- 3.6 With the brake off, insert retraction screw and screw it fully in; finger tight is sufficient. (If thruster will not retract, the brake should be released using the retraction screw, which should be well lubricated). Disconnect the air supply and remove thruster from caliper.

Adjust the retraction screw to allow a thruster stroke of approximately 32mm (i.e. just under full stroke). This adjustment allows the diaphragm to assume its natural shape, which eases re-assembly. The use of a temporary air supply will be found convenient, as it avoids having to turn the retraction screw under load.

Withdraw the bolts (21), and remove the front cap (1), spring ring (17), support plate (16) and diaphragm (15). The diaphragm should be free from splits or cracks, but some wear from the edge of the spring plate (11) is acceptable if the fabric reinforcement is not damaged.

GMR-S and GMR40-S Disc Brake Caliper - Spring Applied, Air Released

- 3.7 Leakage of air past the rod seal may be caused by damage to the seal or to the pushrod. The surface of the pushrod must be smooth and free from scoring or bruising. Note that the pushrod cannot be removed whilst the thruster is dismantled. (For removal and replacement of the push rod see 3.11 below).

The rod seal (which has two parts, the P.T.F.E. sealing ring and an O-ring) may be removed using a small screwdriver or similar tool. Take care not to damage the groove. Once removed the seal should not be re-used.

When fitting a new seal, the P.T.F.E. ring must be compressed, which requires the use of a fitting tool; see drawing A21123. Note that the stepped side of the ring is the pressure side.

- 3.8 The wiper seal (7) serves both to retain grease and to exclude dirt. The section of the pushrod which moves through the wiper seal should be cleaned with a very slight lubricant film. The wiper seal is of all rubber construction and is easily replaced without tools.
- 3.9 The bush (30), which is pressed into the front cap, has a number of shallow circular indentations in its surface, which retain grease. The limit of acceptable wear on the bush is 0.2mm, approximately half the depth of the indentations in a new bearing.

A worn bush can be withdrawn (after removal of the wiper seal which may be re-used unless damaged) using a suitable extractor. The new bush, should be pressed in until flush with the base of the wiper seal recess.

- 3.10 Re-assembly of the thruster is the reverse of dismantling. Seals should be lightly greased to ease assembly; the grease reservoir groove in the front cap and the bush indentations should be filled with grease.

Ensure that the beaded edge of the diaphragm locates correctly in the grooves, and tighten the bolts progressively until flanges are in contact all round.

After re-assembly, pressurise the thruster and check for leaks. Using the retraction screw to maintain full retraction, refit the thruster to the caliper. (After removing the retraction screw replace the red plastic cap in the hole).

Push rod removal/replacement Re-Lubrication of Thruster

- 3.11 With the thruster removed from the caliper (as in 3.6), remove the retraction screw, so that the thruster operates through its full stroke, and the spring load is supported on the front cap. Remove the thrust collar (3) from the rear cap (2). This is a light press fit.

Unscrew the pushrod until it can be withdrawn through the rear of the thruster. Clean and examine the push rod, replace if damaged. Clean other parts.

Re-lubricate the front cap bearing, the internal thread of the sleeve (10), the rear cap bore adjacent to the end of the sleeve, and the threads (internal and external) of the push rod, with grease.

Re-fit the pushrod into the thruster and replace the thrust collar (if it is loose, use a low-strength grade of 'Loctite' to retain it). Pressurise the thruster, check for leaks and fit the retraction screw. Re-fit the thruster to the caliper. (After removing the retraction screw, replace the red plastic cap into the hole).

4. Recommended Lubricants

- 4.1 Caliper: Medium grease containing Molybdenum disulphide.
e.g. Castrol LMM
Shell Alvania 2 + MoS²
- 4.2 Thruster: Medium lithium based grease with rust inhibitors
e.g. Duckham's Keenomax L2
Castrol AP 2
Shell Alvania R2

5. Spares

- 5.1 A spare set of brake pads, a diaphragm and a set of seals should be kept in a cool, dry, dark place where there is no chance of contamination.
- 5.2 For caliper spares see Data Sheet DB 3604.
- 5.3 Spare components for air-line equipment, including the filters and the controller should be kept in readiness, as appropriate.

6. Service

Address all enquiries regarding this equipment to Howdon Power Transmission Ltd

GMR-S and GMR40-S Disc Brake Caliper - Spring Applied, Air Released

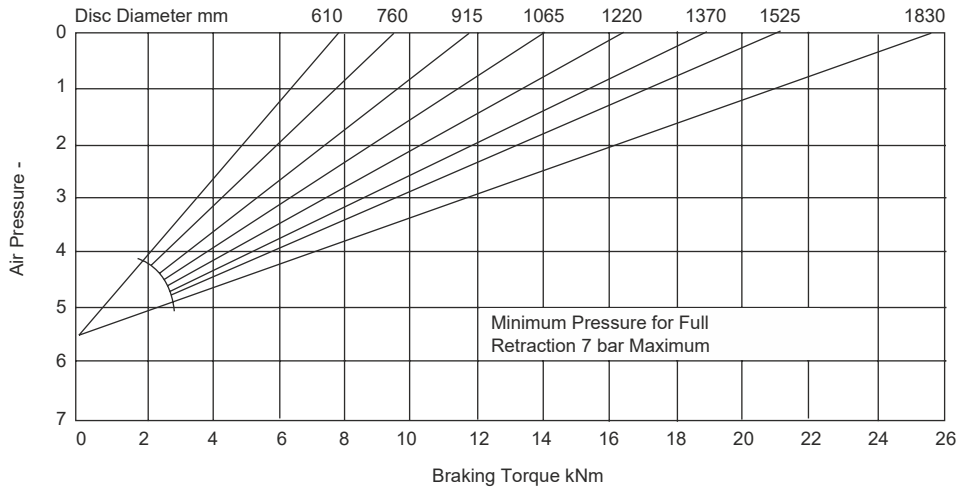

Brake performance at 30 kN braking force

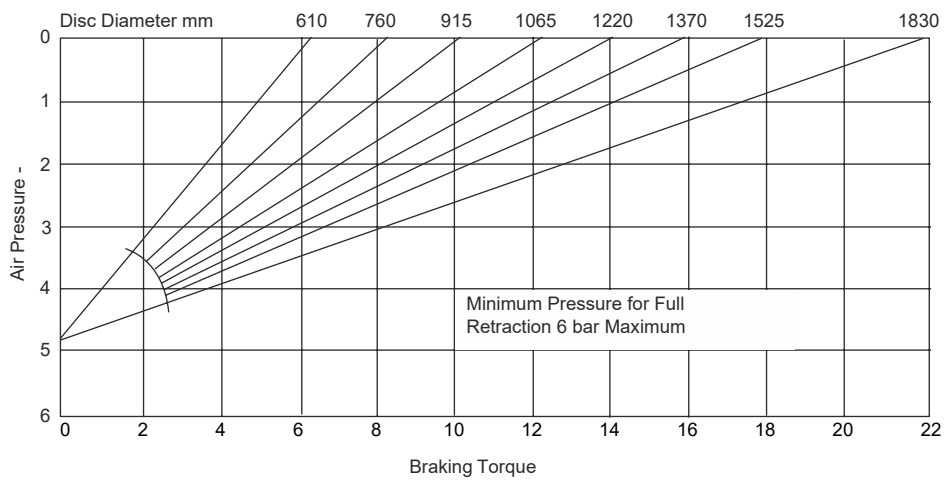

Brake performance at 25 kN braking force

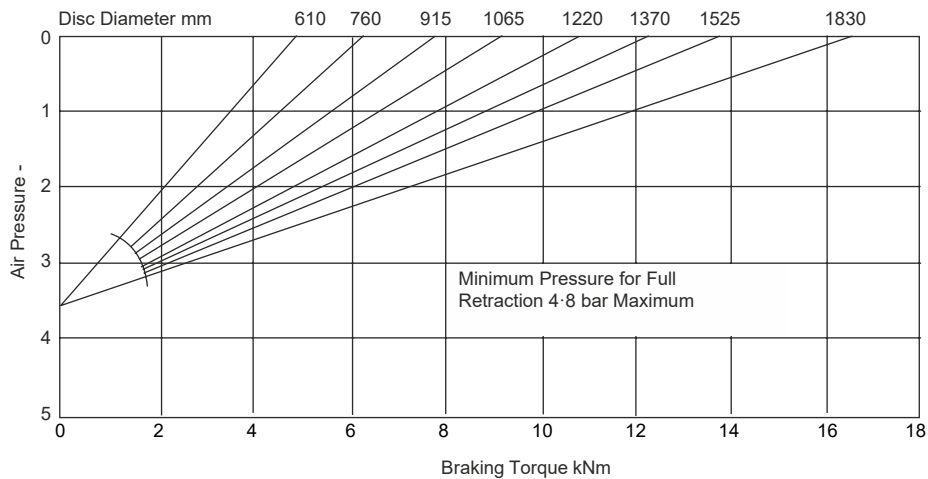

1 kNm = 736.6 lbf-ft 1 bar = 14.5 psi

Brake performance at 19.5 kN braking force



This approval is in Accordance with
 Certificate number 850822
 Issue 04 June 2009 © Twiflex 2001 Issue 05

Tel: +44 (0)1453 750814
 Fax: +44 (0)1453 765320
www.howdon.co.uk
sales@howdon.co.uk