

MXH Disc Brake Caliper - Mechanically Applied, Lever Operated

Nominal dimensions given
For caliper dimensions see DS2500

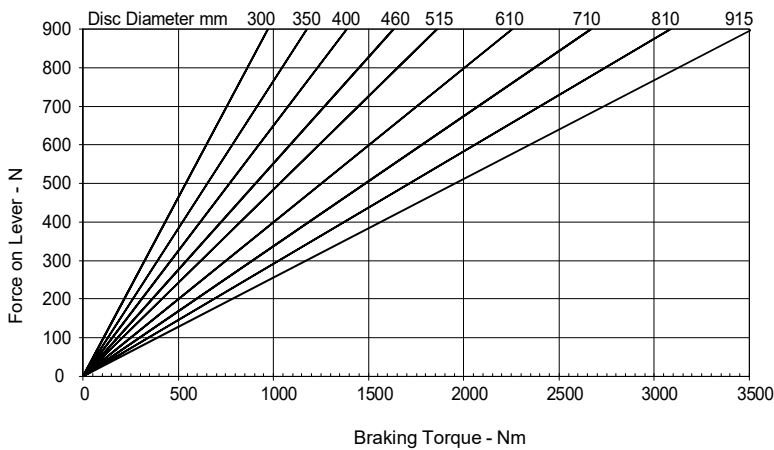
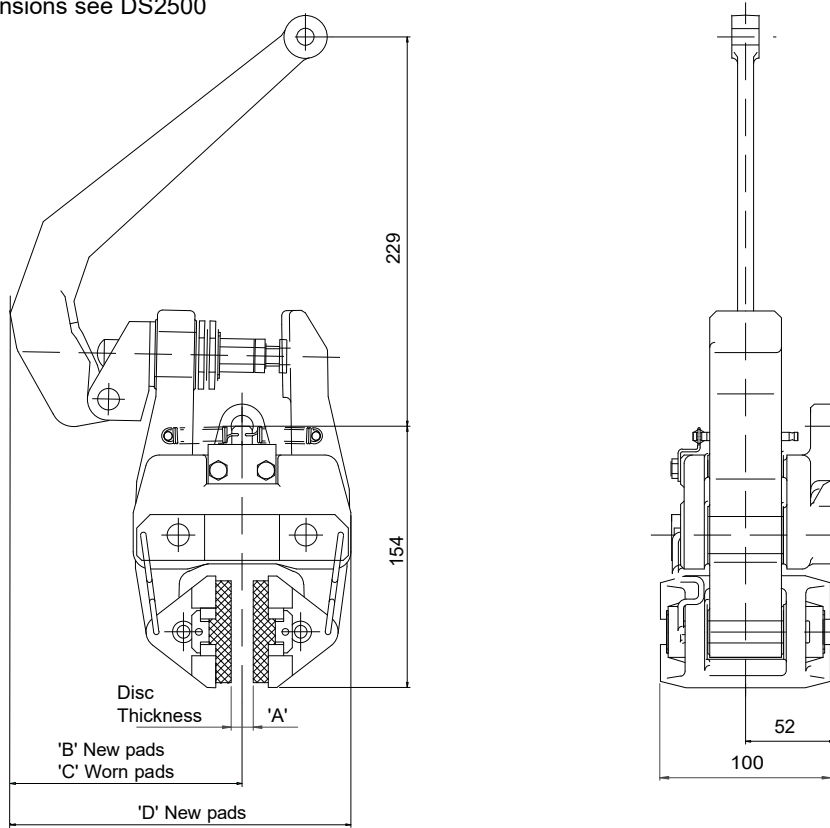

Caliper	Dimensions in mm			
	A	B	C	D
MXH 13	13	140.5	148.5	205.5
MXH 25	25	145	153	212
MXH 30	30	140.5	148.5	211.5
MXH 40	40	145	153	220

Weight (caliper and lever assembly) - 8.4kg
(lever assembly only) - 1.4kg

Maximum Braking Force = 8.3kN @ 0.9kN force on lever

The ratings shown on the above graph are based on fully bedded and conditioned brake pads with nominal friction coefficient $\mu = 0.4$.

For bedding-in and conditioning procedures see Publication M1060.

Braking Force is defined as the Tangential Force acting on the brake disc at the Effective Disc Radius.
Braking Torque (Nm) = Braking Force (N) x Effective Disc Radius (m) where Effective Disc Radius = Actual Disc Radius - 0.033.

Twiflex Disc Brakes must be used with Twiflex asbestos free brake pads. The use of any other brake pads will invalidate the warranty. Twiflex Limited reserves the right to modify or change the design without prior notice.

MXH Disc Brake Caliper - Mechanically Applied, Lever Operated

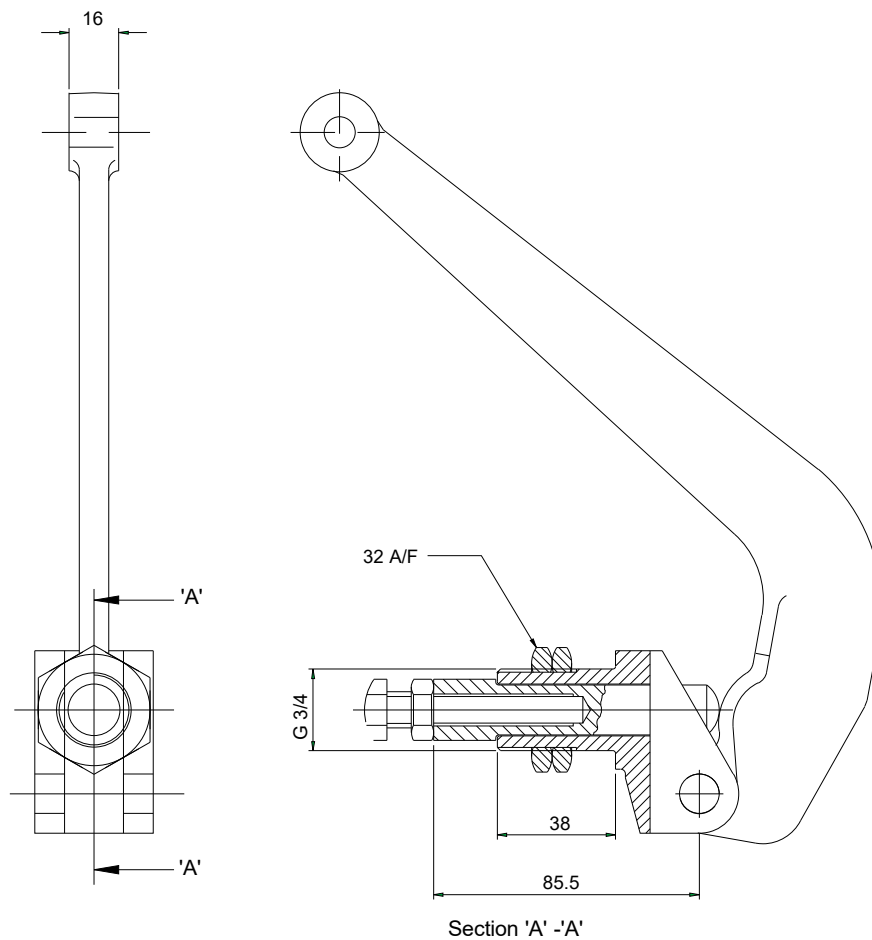

Lever assembly part number 7800125

Lever fitment

1. Offer lever to caliper making sure that both lock nuts are removed before placing push rod through caliper arm.
2. Fit lock nuts over the push rod and locate it's end within the slot of the other arm.
3. Tighten one lock nut to 50-60 Nm then tighten the second nut against the first.

