

MS100 Disc Brake Caliper

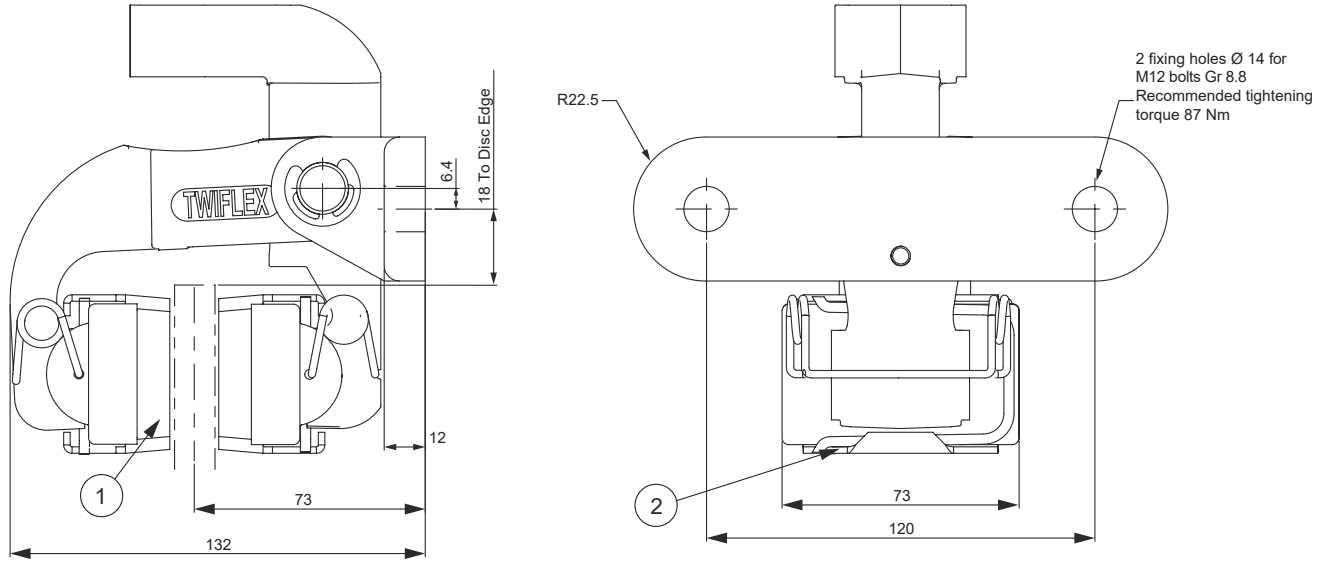

Caliper Part Number. 6702226

Caliper Part Number. 6702305 for K and L Thrusters

- Weight - 3.9 kg
- Pad wear allowance - 8mm
- Total pad area - 58cm² (2 Pads)
- Pad dimensions new - 63 x 48 x 13.7mm thick
- Pad material - Asbestos-free friction material

AVAILABLE SPARES		
Item	Component	Part No.
1	Pad Assembly	0780123-W
2	Spring Clip	7908688

Twiflex Disc Brakes must be used with Twiflex asbestos free brake pads. The use of any other brake pads will invalidate the warranty.

Twiflex Limited reserves the right to modify or change the design without prior notice.

MS100 Disc Brake Caliper

General Description

The MS100 series of disc brake calipers are used with brake discs 12-15mm thick. Normally one or two units will be used per disc but the number may be increased, depending on disc size. The brake units can be positioned at any angle around the periphery of the disc, but ideally they should be mounted horizontally (in 3 or 9 o'clock positions) in relation to the disc.

Thruster	Description	Maximum Braking Force - kN
A	Pneumatically applied - Spring released	2.76
D	Pneumatically applied - Spring released	1.44
E	Pneumatically applied - Spring released	0.29
F	Mechanically applied - Lever operated	1.88
G	Pneumatically applied - Spring released	0.76
H	Mechanically applied - Hand operated	1.01
K	Spring applied - Pneumatically Released	0.87, 1.74 and 2.6
L	Spring applied - Hydraulically Released	0.87, 1.74 and 2.6

Discs:

A range of standard discs of 12.7mm thick are available from Twiflex see Data Sheet DB5002. Minimum disc diameter for the MS100 caliper is 150mm.

Effective disc radius = actual disc radius – 0.033m

Pad replacement:

To replace the pads, secure the installation to ensure safety. Ease out the pad retaining springs and remove worn pads. Clean the disc and pad mounts with a suitable cleaning agent such as white spirit. Fit new pads. Replace retaining springs.

For bedding-in and conditioning procedures see Publication M1060

Health and Safety data sheet refer to DS0500



This approval is in Accordance with
Certificate number 850822
Issue 04 June 2009 © Twiflex 2001.

Tel: +44 (0)1453 750814
Fax: +44 (0)1453 765320
www.howdon.co.uk
sales@howdon.co.uk