

VKSD Disc Brake Caliper - Spring Applied, Hydraulically Released

See Publication Ref. No.M1030 Installation, Operation and Maintenance.

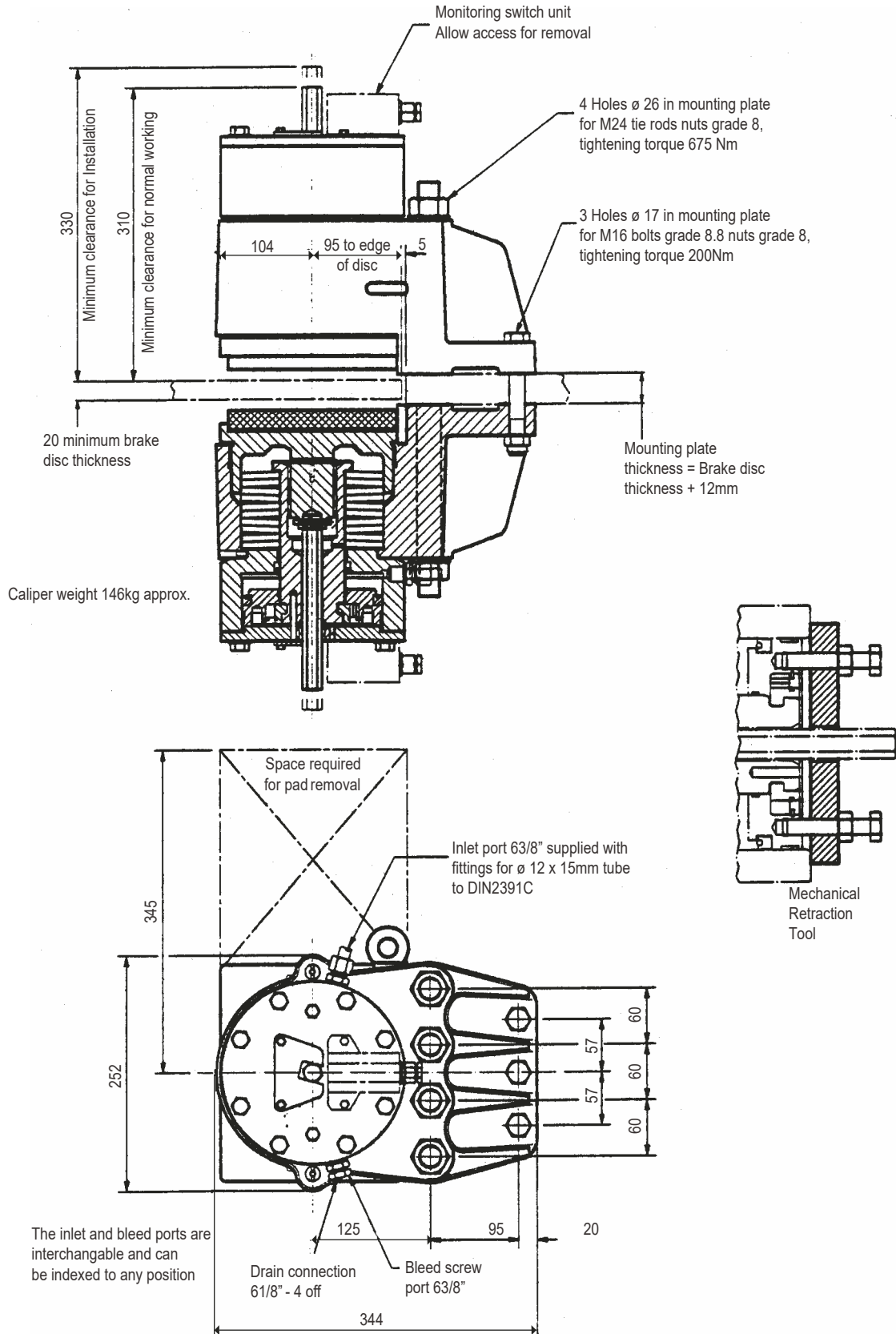

VKSD Disc Brake Caliper - Spring Applied, Hydraulically Released

Technical Data:

BRAKE DISC

- Diameter - 1000mm minimum. There is no maximum limit except for practical considerations
- Thickness - 20mm minimum. There is no maximum limit except for practical considerations
- Material - standard discs sg iron to BS 2789 grade 420/1 2. (Twiflex data sheet DB 5002)
- Finish - brake path surface to be 2µm or better.

BRAKE PADS	Length Allowance	Width	Thickness	Area(2 pads)	Wear
	208mm	180mm	22mm	748.8cm ²	10mm

HYDRAULICS

The recommended fluid is mineral oil based hydraulic fluid. Correctly formulated water-in-oil emulsions may also be used. Fluid displacement for 1 mm retraction at both pads - 28ml.

BRAKE ADJUSTMENTS

The adjusting screw sets the air gap between brake pad and brake disc and allows brake pad wear to be taken up. In a high wear situation, re-setting should be frequent. See Installation, Operation and Maintenance Instructions for adjustment for pad wear. Monitoring units are optionally available to indicate a) brake off, b) wear adjustment required and c) pad replacement required.

MECHANICAL RETRACTION

A mechanical retraction tool is supplied. and should only be used to release the brake in emergencies such as hydraulic supply failure. A failed seal would also necessitate the use of a mechanical retraction tool.

Performance Data:

Caliper VKSD	Air Gap Setting mm	Braking force kN	Pressure to Release Brake bar	Min. For fill Retraction bar	Max Type Allowable Pressure bar
High	2	119	124	138	163
High	2	112	116	131	156
High	2	102	108	124	149
High	2	96.3	100	116	141
High	2	88.2	92	108	133
High	2	80	83	100	125
High	2	71.2	75	92	117
High	2	62.4	65	83	109
Low	2	64.1	63	69	94
Low	2	58.7	58	63	88
Low	2	53	53	58	83
Low	2	47.1	47	53	78
Low	2	41	41	47	72
Low	2	34.4	34	41	66
Low	2	27.8	28	34	59

Braking force assumes -
a) a coefficient of friction between brake pad and brake disc of 0.4"
b) a small loss due to spring pack friction
c) an air gap setting as stated in the table Braking force is increased by reduction in air gap setting and vice versa.

Pressures stated allow for a small loss due to seal friction.

* This is only achieved by fully bedded-in and conditioned brake pads and a high standard of cleanliness and dryness at the friction surfaces. A bedding-in procedure is available in publication M1065.

An appropriate service factor should be applied according to the duty. In the case of holding brakes or wet conditions this should be at least 2.

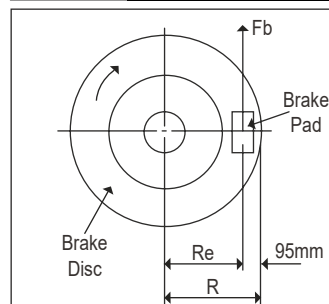

Braking Torque

Braking Torque (Tb) = Braking Force (Fb) x Effective Disc Radius (Re)
Effective Disc Radius (Re) = Actual Disc Radius (R) - 0.095m
For Tb in Nm. apply Fb in Newtons and R in metres
 $Tb = Fb \times Re$ (Re = R - 0.095m) Tb
= Fb (R - 0.095) Nm
For Tb in lbf ft. apply Fb in lbf and R in ft. Tb
= Fb (R - 0.512ft.) lbf ft.

Twiflex disc brakes must be used with Twiflex asbestos free pads. The use of any other brake pad will invalidate the warranty. Twiflex Limited reserves the right to modify or change the design without prior notice. This document is the intellectual property of Twiflex Limited.



This approval is in Accordance with Certificate number 850822 Issue 04 June 2009 © Twiflex 2001

Tel: +44 (0)1453 750814
Fax: +44 (0)1453 765320
www.howdon.co.uk
sales@howdon.co.uk