

**MSL Disc Brake Caliper - Spring Applied, Hydraulically Released**

Nominal dimensions given  
For caliper dimensions see DS1500

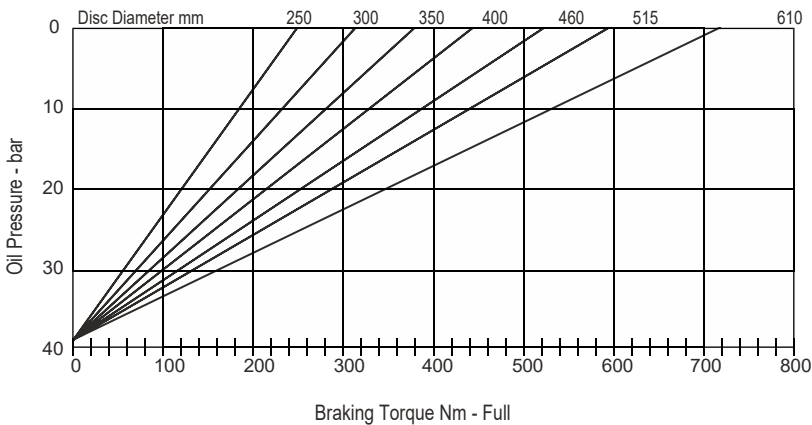
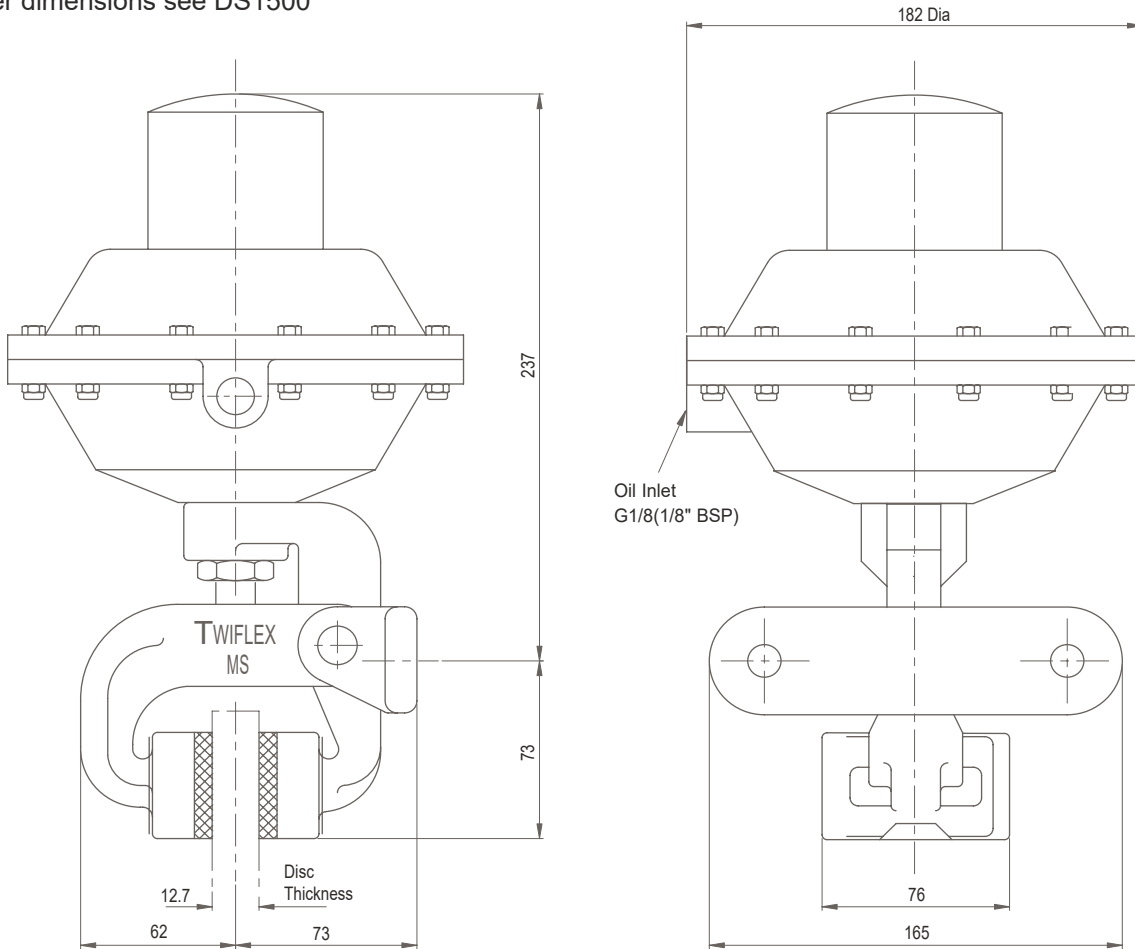

Weight (caliper and thruster) - 5.5kg  
(thruster only) - 4.0kg  
Volume displacement of thruster at 4mm retraction = 5ml.

**Maximum working pressure 120 bar**

Rate	Maximum Braking Force - kN [lbf]	Minimum Pressure for Full Retraction - bar [psi]
Full	2.67	50
2/3	1.74	33
1/3	0.87	17

The ratings shown on the above graph are based on fully bedded and conditioned brake pads with nominal friction coefficient  $\mu = 0.4$ .

For bedding-in and conditioning procedures see Publication M1060.

Braking Force is defined as the Tangential Force acting on the brake disc at the Effective Disc Radius.

Braking Torque (Nm) = Braking Force (N) x Effective Disc Radius (m) where Effective Disc Radius = Actual Disc Radius - 0.03.

Twiflex Disc Brakes must be used with Twiflex asbestos free brake pads. The use of any other brake pads will invalidate the warranty.

Twiflex Limited reserves the right to modify or change the design without prior notice.

# MSL Disc Brake Caliper - Spring Applied, Hydraulically Released

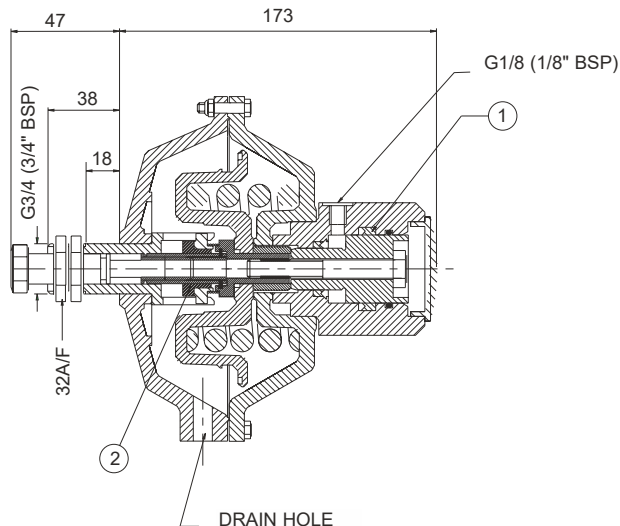
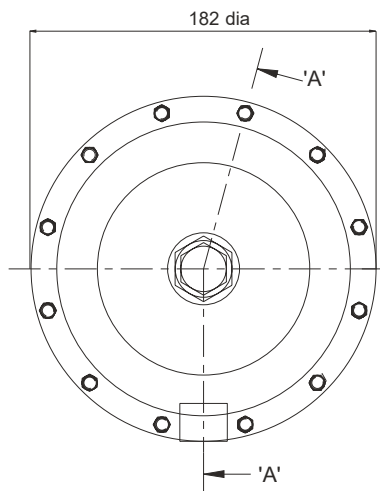

Available Spares		
Item	Component	Part No.
1	Seal Kit	7902806
2	Self Adjusting Repair Kit	7902805

## Thruster Part Numbers

MSL Full rate 7500124/AH40

MSL 2/3rd rate 7500125/AH41

MSL 1/3rd rate 7500126/AH42

Non self adjusting versions are available - contact Twiflex for details.

Depending upon the service conditions it may eventually become necessary to replace the hydraulic seals. This is done as follows:

- Remove thruster from caliper.
- Unscrew and remove the pushrod.
- Remove the end cap from the rear of the thruster. (see drawing above)
- Unscrew M10 bolt. (see drawing above)
- Gently apply hydraulic pressure at inlet port to ease the piston out of the cylinder.
- The seal and O Ring can now be replaced on the piston and also the one in the cylinder. (see drawing above)
- Lightly grease the seals and replace piston and lock in position with M10 bolt, tightening torque 46Nm. (use Loctite)
- Replace the end cap and the thruster is ready for service.

## Thruster Fitment

- Make sure the thruster rod is extended i.e. it is not pressurised.
- Take hold of the thruster and turn the push rod via the hex portion clockwise until it stops rotating so a 'clicking' can be heard from the ratchet. Do this by hand, do not apply heavy force to push the rod once it stops turning.
- Offer thruster to caliper making sure that both lock nuts are removed before placing hex section of push rod through caliper arm.
- Pull caliper arms apart so that the pads are hard against the disc.
- Fit lock nuts to thruster body loosely and unwind push rod until the gap between the body and the arm is 6mm. Make sure that the hex section of the push rod is within the slot of the other arm.
- Tighten first lock nut to 50 - 60Nm then tighten the second nut against the first .
- Fit tension spring to arms.

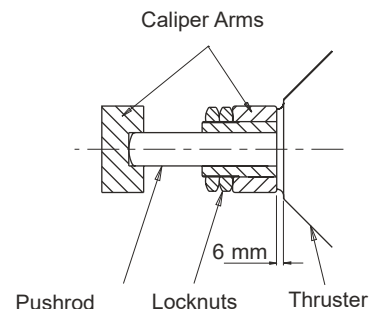

This approval is in Accordance with  
Certificate number 850822  
Issue 04 June 2009 © Twiflex 2001

Tel: +44 (0)1453 750814  
Fax: +44 (0)1453 765320  
www.howdon.co.uk  
sales@howdon.co.uk