

MSK Disc Brake Caliper - Spring Applied, Pneumatically Released

Nominal dimensions given
For caliper dimensions see

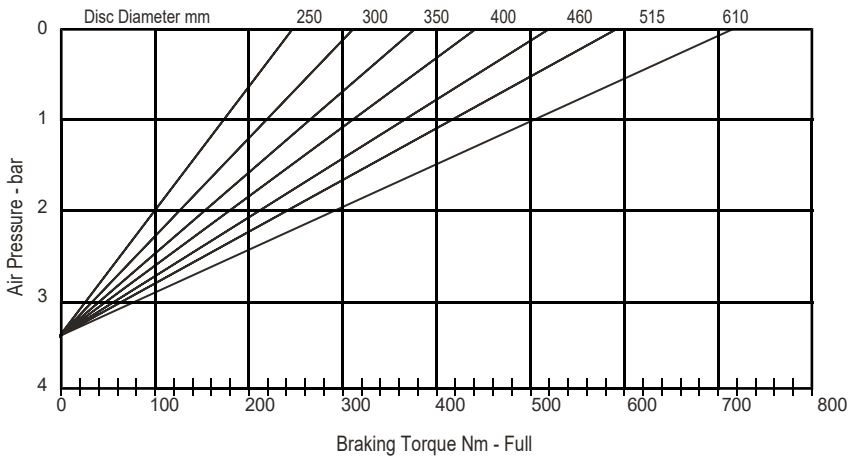
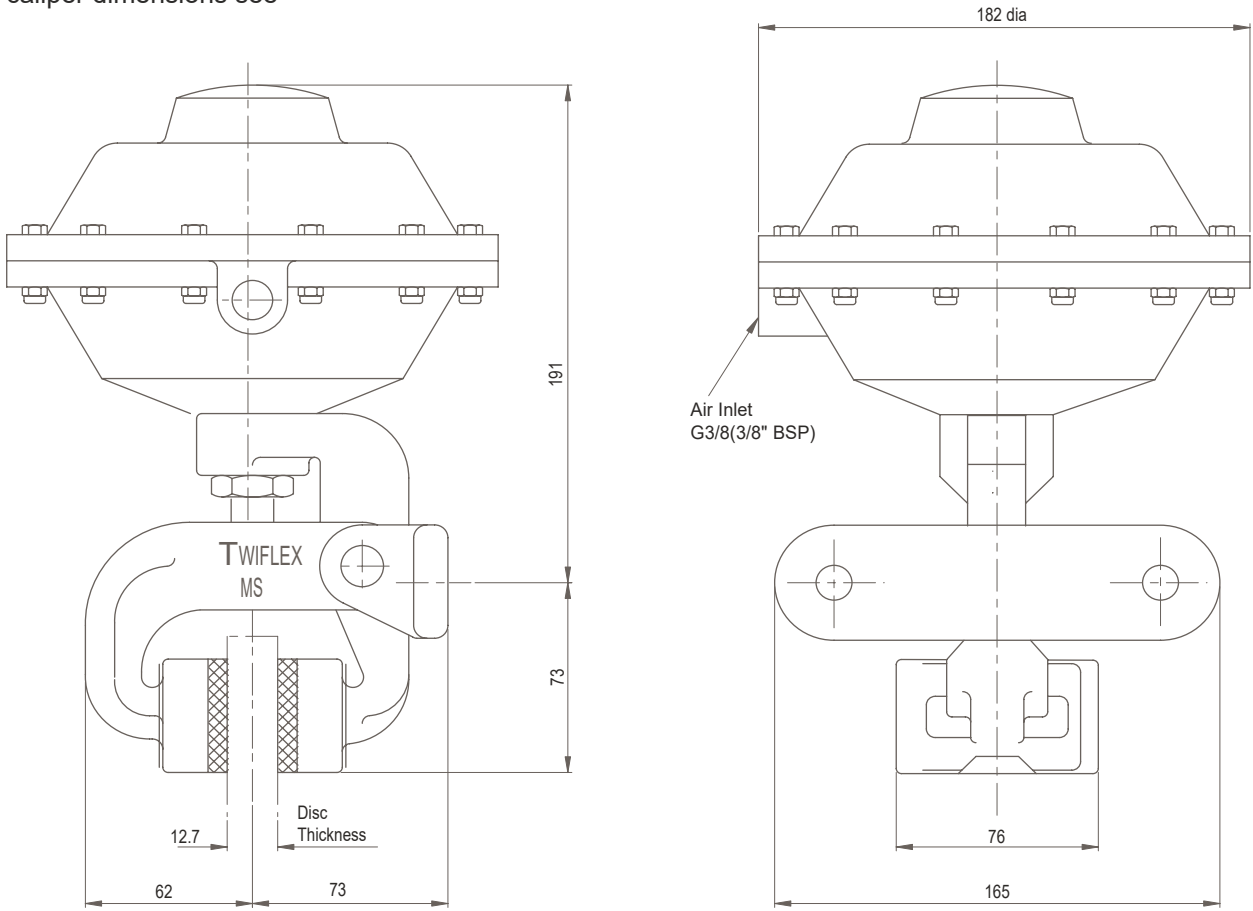

Weight (caliper and thruster) - 4.9kg
Weight (thruster only) - 3.4kg
Volume displacement of thruster at full retraction = 0.95l.

Maximum working pressure 7 bar

Rate	Maximum Braking Force - kN [lbf]	Minimum Pressure for Full Retraction - bar [psi]
Full	2.6	5
2/3	1.74	3.3
1/3	0.87	1.7

The ratings shown on the above graph are based on fully bedded and conditioned brake pads with nominal friction coefficient $\mu = 0.4$.

For bedding-in and conditioning procedures see Publication M1060.

Braking Force is defined as the Tangential Force acting on the brake disc at the Effective Disc Radius.

Braking Torque (Nm) = Braking Force (N) x Effective Disc Radius (m) where Effective Disc Radius = Actual Disc Radius - 0.03.

Twiflex Disc Brakes must be used with Twiflex asbestos free brake pads. The use of any other brake pads will invalidate the warranty.

Twiflex reserves the right to modify or change the design without prior notice.

MSK Disc Brake Caliper - Spring Applied, Pneumatically Released

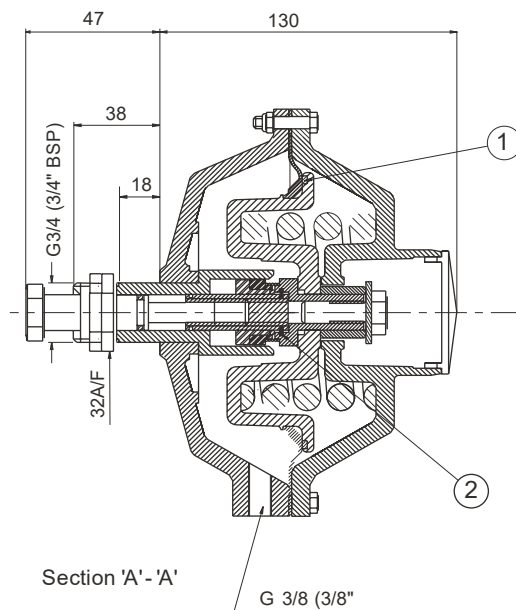
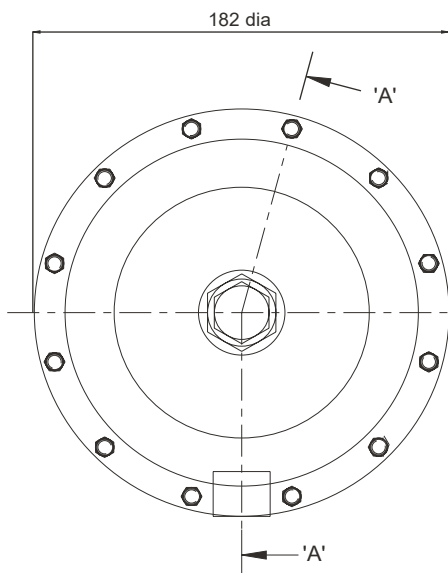

Available Spares		
Item	Component	Part No.
1	Diaphragm Kit	7902804
2	Self Adjusting Repair Kit	7902805

Thruster Part Numbers

MSK Full rate 7200626
 MSK 2/3rd rate 7200862
 MSK 1/3rd rate 7200698

This range of pneumatically operated brakes uses dry and filtered compressed air at pressures up to 7 bar. Pneumatic brakes require a control valve which may be operated either manually, or by pneumatic or electrical signal.

Should it become necessary to replace a diaphragm, Remove from caliper and ensure air supply is disconnected. Unscrew and remove push rod. Remove the M5 bolts and the rear cap of the thruster. Remove the worn diaphragm; clean-up the contacting surfaces and re-assemble with the new diaphragm and M5 bolts in position (Tightening Torque 5.7Nm).

Thruster Fitment with Thruster Unpressurised

1. Take hold of the thruster and turn push rod clockwise' using the hexagonal portion, until it stops retracting: at this point a clicking noise from the ratchet will be heard. Do this by hand, do not use excessive force.
2. Remove the lock nuts and offer the thruster to the caliper, passing the hexagonal end of the push rod through the arm. Loosely re-fit the lock nuts.
3. Unscrew the push rod until the gap between the arm and the thruster body is 6 mm, when the hexagon is located in the slot in the opposite arm, and the pads are in firm contact with the disc.
4. Tighten the inner lock nut to 50~60 Nm; this will compress the thruster spring and reduce the gap to zero. Then tighten the second lock nut against the first.

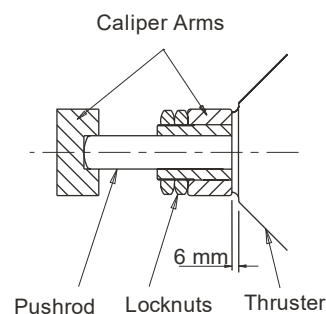

This approval is in Accordance with
 Certificate number 850822
 Issue 04 June 2009 © Twiflex 2001 Issue 05

Tel: +44 (0)1453 750814
 Fax: +44 (0)1453 765320
www.howdon.co.uk
sales@howdon.co.uk