

MSE Disc Brake Caliper - Pneumatically Applied, Spring Released

Nominal dimensions given
For caliper dimensions see DS1500

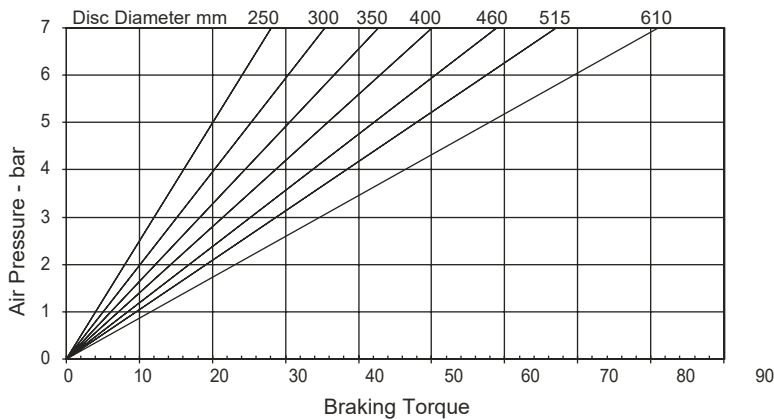
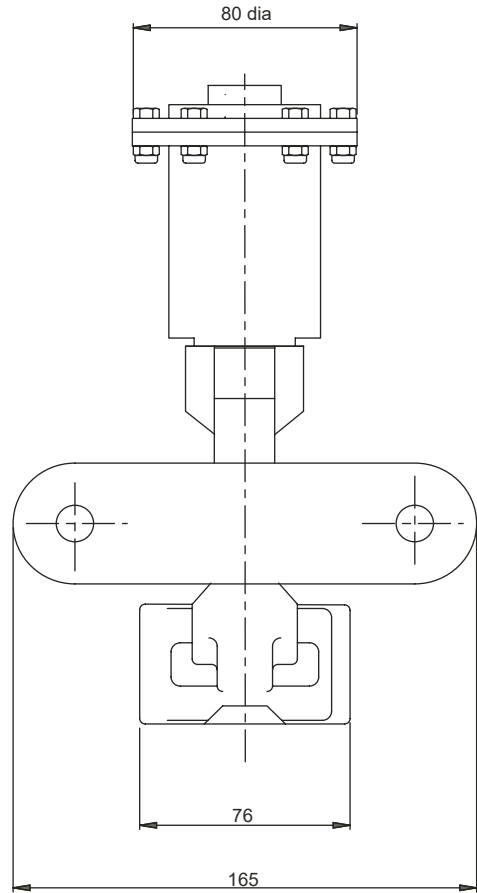
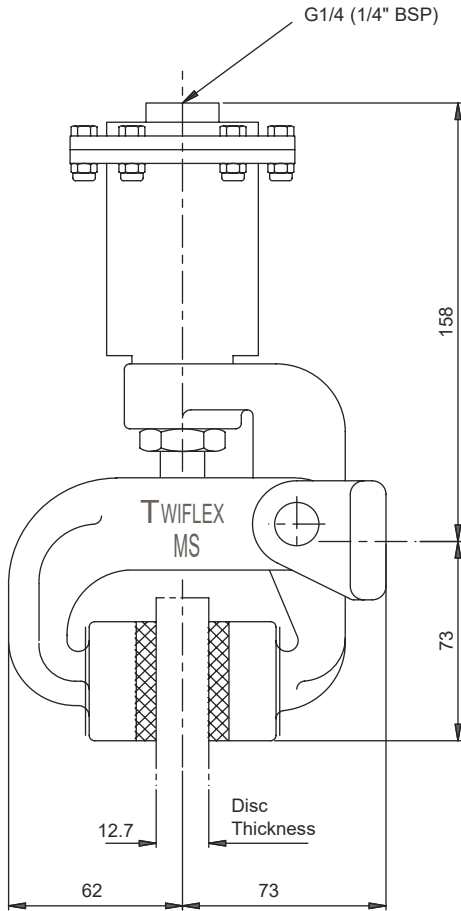

Weight (caliper and thruster) - 1.91kg
(thruster only) - 0.41kg
Volume displacement of thruster at full stroke is 8ml.

Maximum pressure 7 bar

Maximum Braking Force = 0.29kN @ 7 bar

The ratings shown on the above graph are based on fully bedded and conditioned brake pads with nominal friction coefficient $\mu = 0.4$.

For bedding-in and conditioning procedures see Publication M1060.

Braking Force is defined as the Tangential Force acting on the brake disc at the Effective Disc Radius.
Braking Torque (Nm) = Braking Force (N) x Effective Disc Radius (m) where Effective Disc Radius = Actual Disc Radius - 0.03.

Twiflex Disc Brakes must be used with Twiflex asbestos free brake pads. The use of any other brake pads will invalidate the warranty.

Twiflex Limited reserves the right to modify or change the design without prior notice.

MSE Disc Brake Caliper - Pneumatically Applied, Spring Released

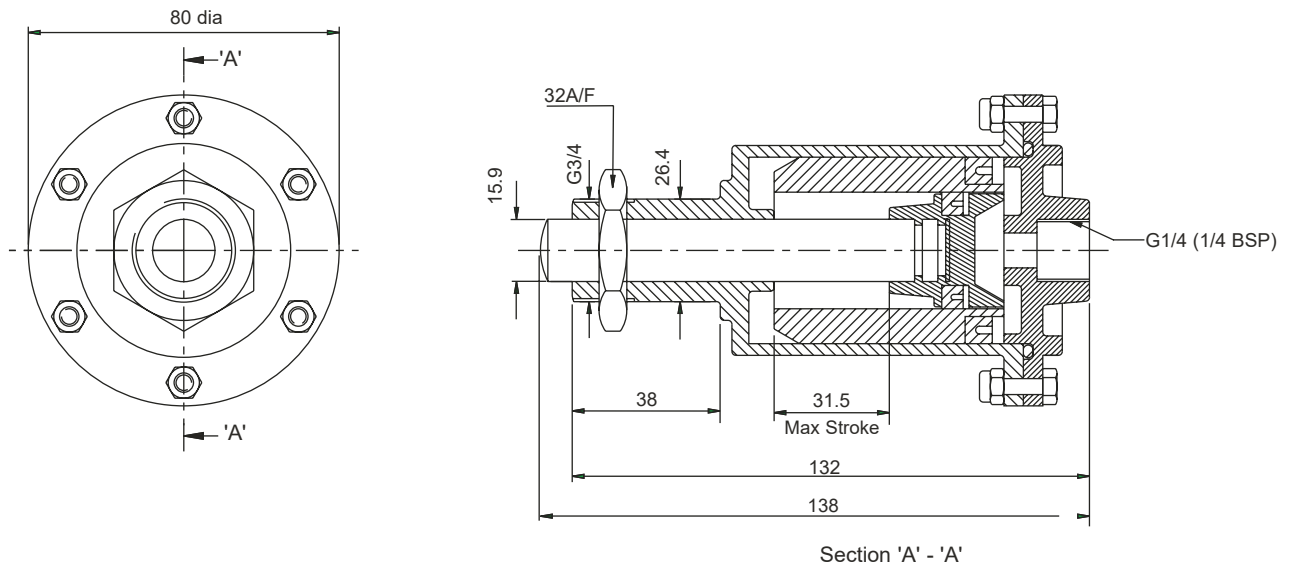

Thruster Part Number 7200479

This range of pneumatically operated brakes uses dry and filtered compressed air at pressures up to 7 bar. Pneumatic brakes require a control valve which may be operated either manually, or by pneumatic or electrical signal.

Thruster Fitment

1. Offer thruster to caliper making sure that the lock nut is removed before placing push rod through caliper arm.
2. Fit lock nut over the push rod and locate its end within the slot of the other arm.
3. Tighten the lock nut to 50-60 Nm.

