

MSA Disc Brake Caliper - Pneumatically Applied, Spring Released

Nominal dimensions given
For caliper dimensions see DS1500

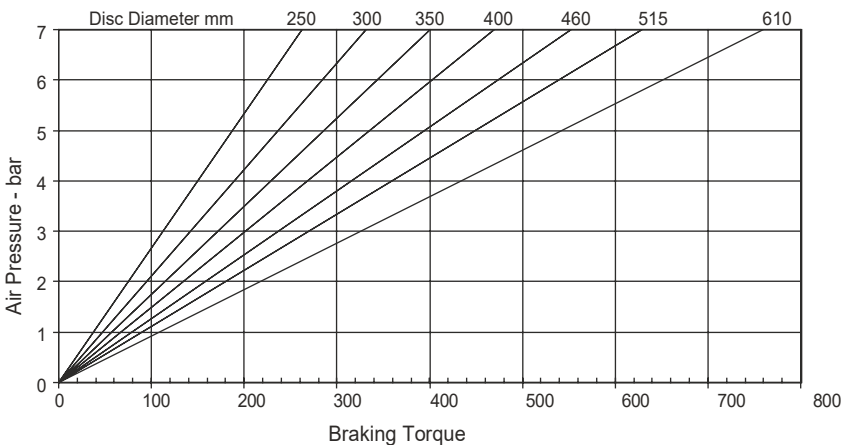
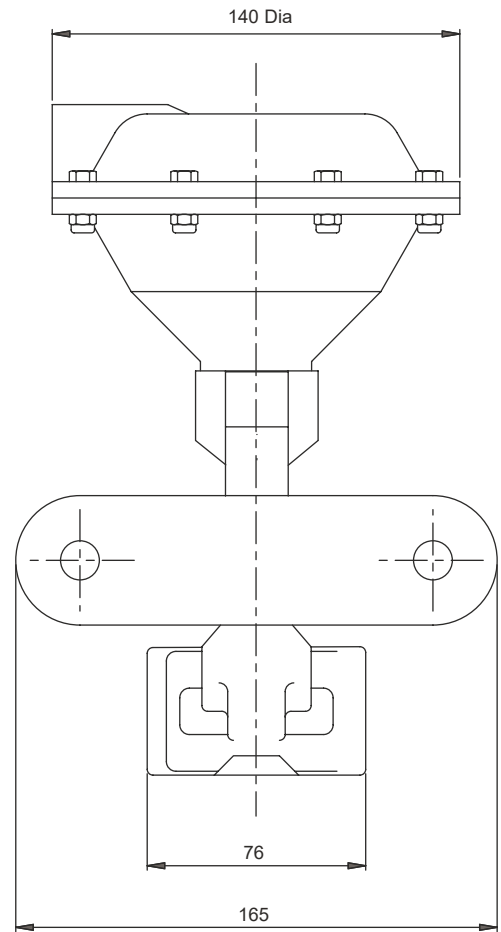
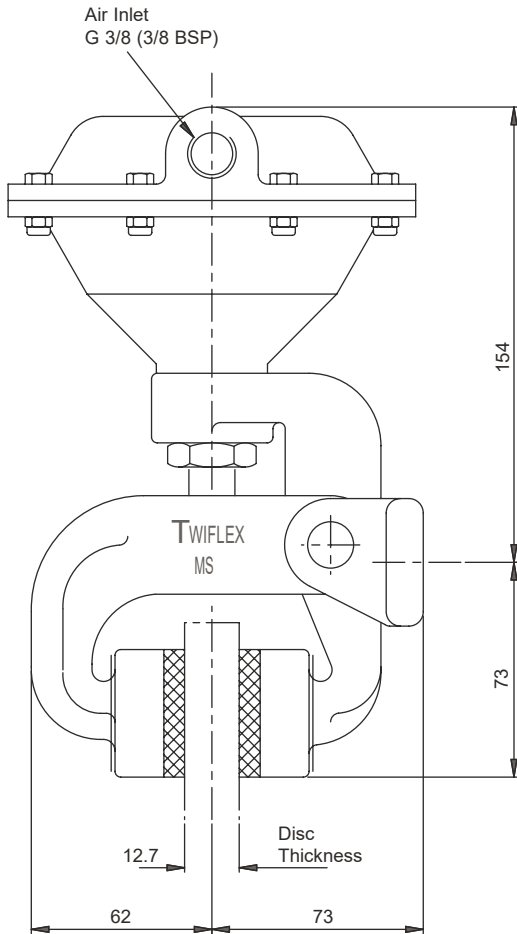

Weight (caliper and thruster) - 2.8kg
(thruster only) - 1.3kg

Volume displacement of thruster at full stroke is 300ml.

Maximum Braking Force = 2.76kN @ 7 bar

The ratings shown on the above graph are based on fully bedded and conditioned brake pads with nominal friction coefficient $\mu = 0.4$.

For bedding-in and conditioning procedures see Publication M1060.

Braking Force is defined as the Tangential Force acting on the brake disc at the Effective Disc Radius.
Braking Torque (Nm) = Braking Force (N) x Effective Disc Radius (m) where Effective Disc Radius = Actual Disc Radius - 0.03.

Twiflex Disc Brakes must be used with Twiflex asbestos free brake pads. The use of any other brake pads will invalidate the warranty.

Twiflex Limited reserves the right to modify or change the design without prior notice.

MSA Disc Brake Caliper - Pneumatically Applied, Spring Released

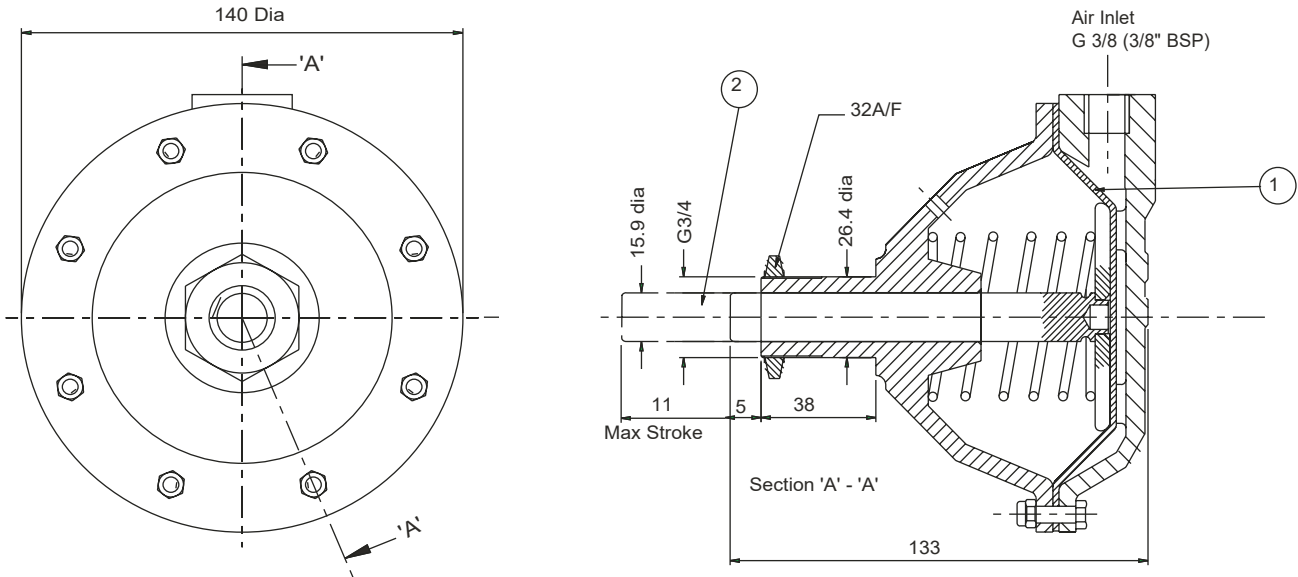

Thruster Part Number 7200276

Available Spares		
Item	Component	Part No.
1	Diaphragm Kit	7902801
2	Piston Rod Assembly	7200494

This range of pneumatically operated brakes uses dry and filtered compressed air at pressures up to 7 bar. Pneumatic brakes require a control valve which may be operated either manually, or by pneumatic or electrical signal.

Should it become necessary to replace a diaphragm, ensure air supply is disconnected, remove the M5 bolts and the rear cap of the thruster. Remove the worn diaphragm, clean-up the contacting surfaces and re-assemble with the new diaphragm and bolts in position (Tightening Torque 5.7Nm).

Thruster Fitment

1. Offer thruster to caliper making sure that the lock nut is removed before placing push rod through caliper arm.
2. Fit lock nut over the push rod and locate it's end within the slot of the other arm.
3. Tighten the lock nut to 50-60 Nm.

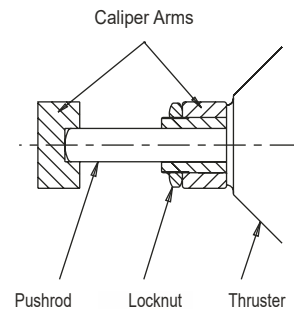

This approval is in Accordance with
Certificate number 850822
Issue 04 June 2009 © Twiflex 2001

Tel: +44 (0)1453 750814
Fax: +44 (0)1453 765320
www.howdon.co.uk
sales@howdon.co.uk