

MS Disc Brake Caliper

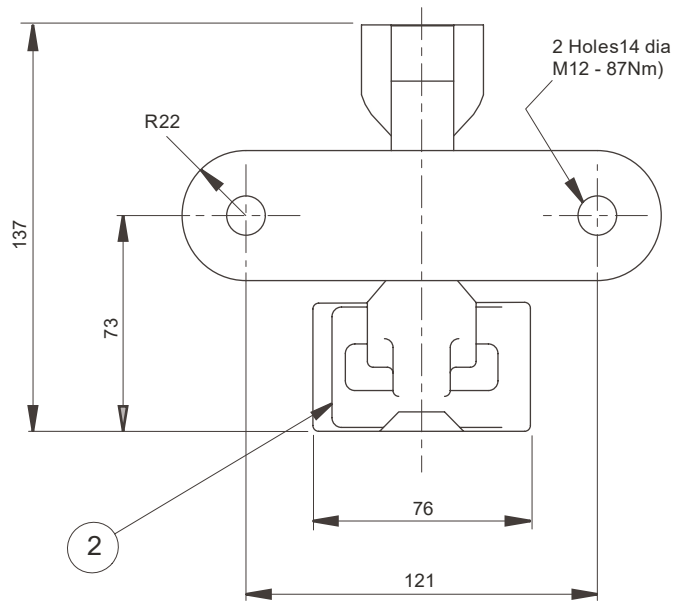
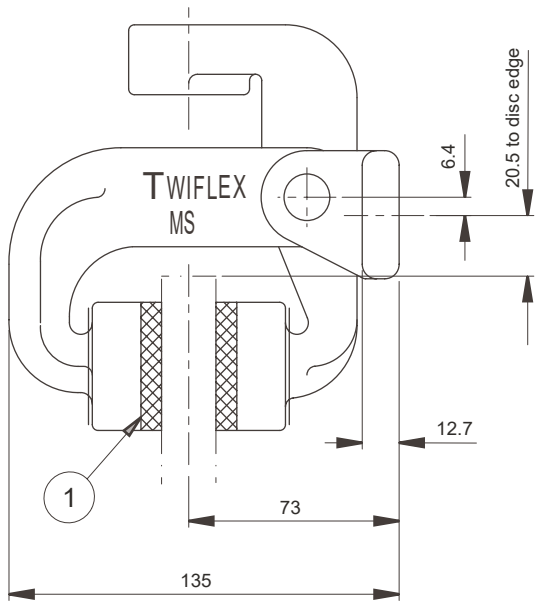

Caliper Part Number. 6780277

Caliper part number. 6780842 for K and L Thrusters

Weight	1.5 kg.
Pad wear allowance	8mm
Total pad area	58cm (2 Pads)
Pad dimensions new	63.5 x 46 x 12.7 thick.
Pad material	Asbestos-free high friction material

Available Spares		
Item	Component	Part No.
1	Pad Assembly	780123
2	Spring Clip	7900024

Twiflex Disc Brakes must be used with Twiflex asbestos free brake pads.
The use of any other brake pads will invalidate the warranty.
Twiflex Limited reserves the right to modify or change the design without prior notice.

MS Disc Brake Caliper

General Description

The MS series of disc brake calipers are used with brake disc 12.7mm thick
Normally one or two units will be used per disc but the number may be increased, depending on disc size.
The brake units can be positioned at any angle around the periphery of the disc, but ideally they should be mounted horizontally (in 3 or 9 o'clock positions) in relation to the disc.

Brake	Description	Data Sheet	Maximum Braking Force - kN
MSA	Pneumatically applied - Spring released	1501	2.76
MSD	Pneumatically applied - Spring released	1502	1.44
MSE	Pneumatically applied - Spring released	1503	0.29
MSF	Mechanically applied - Lever operated	1504	1.88
MSG	Pneumatically applied - Spring released	1505	0.76
MSH	Mechanically applied - Hand operated	1506	1.01
MSK	Spring applied - Pneumatically released	1507	0.87, 1.74 and 2.6
MSL	Spring applied - Hydraulically released	1508	0.87, 1.74 and 2.6

Discs:

A range of standard discs of 12.7mm thick are available from Twiflex see Data Sheet DB5002.
Minimum disc diameter for the MS caliper is 150mm

Controllers:

Standard Twiflex Controllers are available for single or multi-caliper installations for use with electric, pneumatic and hydraulic signalling systems.

Pad replacement:

To replace the pads, secure the installation to ensure safety. Ease out the pad springs and remove worn pads. Clean the disc and pad mounts with a suitable cleaning agent such as white spirit. Fit new pads. Replace pad springs.

For bedding-in and conditioning procedures see publication M1060

Health and Safety data sheet refer to DS 0500



This approval is in Accordance with
Certificate number 850822
Issue 04 June 2009 © Twiflex 2001 Issue 05

Tel: +44 (0)1453 750814
Fax: +44 (0)1453 765320
www.howdon.co.uk
sales@howdon.co.uk