

**DB3605**

**GMR-H and GMR40-H Disc Brake Caliper - Hydraulically Applied, Spring Released**

Nominal dimensions given.  
For specific dimensions  
please contact us.  
For GMR Mk 2 caliper details  
see Data Sheet DB3604.

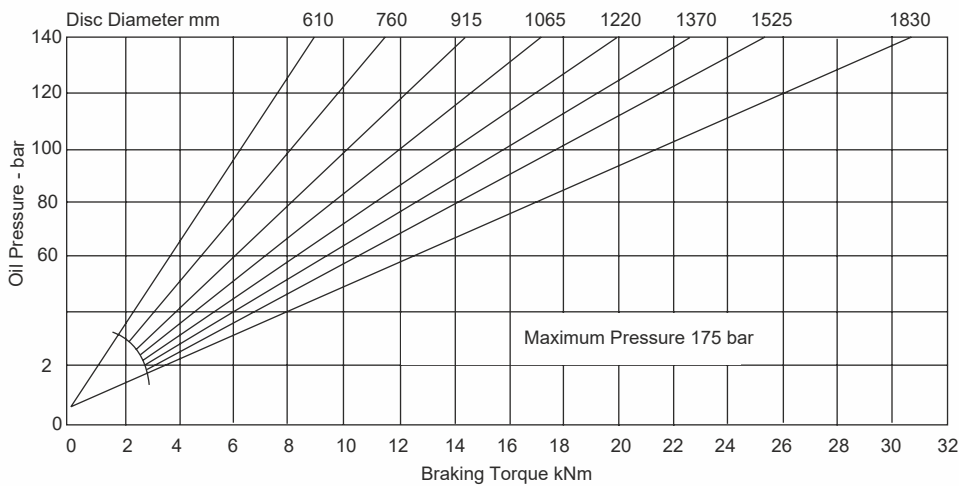
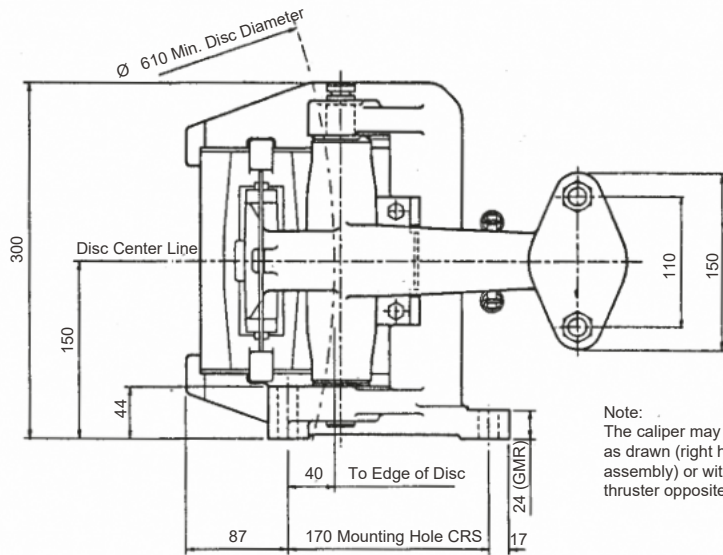
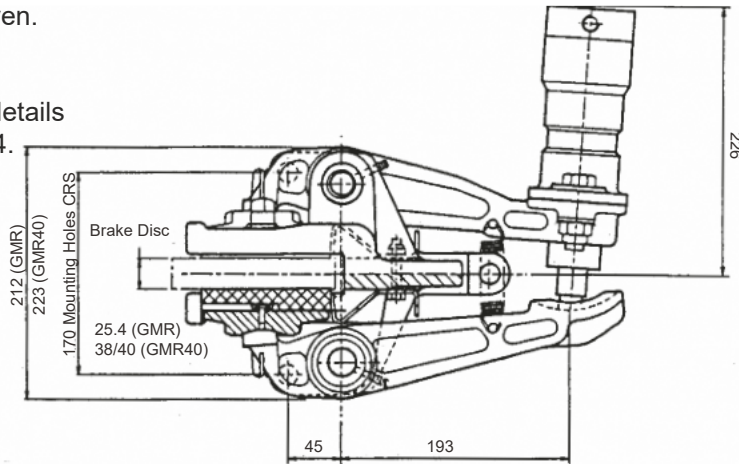

Maximum Braking Force = 36kN @ 140 bar.

The ratings shown on the above graph are based on fully bedded and conditioned brake pads. For bedding in and conditioning procedures see Publication M1060.

Braking Force is defined as the Tangential Force acting on the brake disc at the Effective Disc Radius.

Braking Torque (Nm) = Braking Force (N) x Effective Disc Radius (m) where Effective Disc Radius = Actual Disc Radius - 0.06

# GMR-H and GMR40-H Disc Brake Caliper - Hydraulically Applied, Spring Released

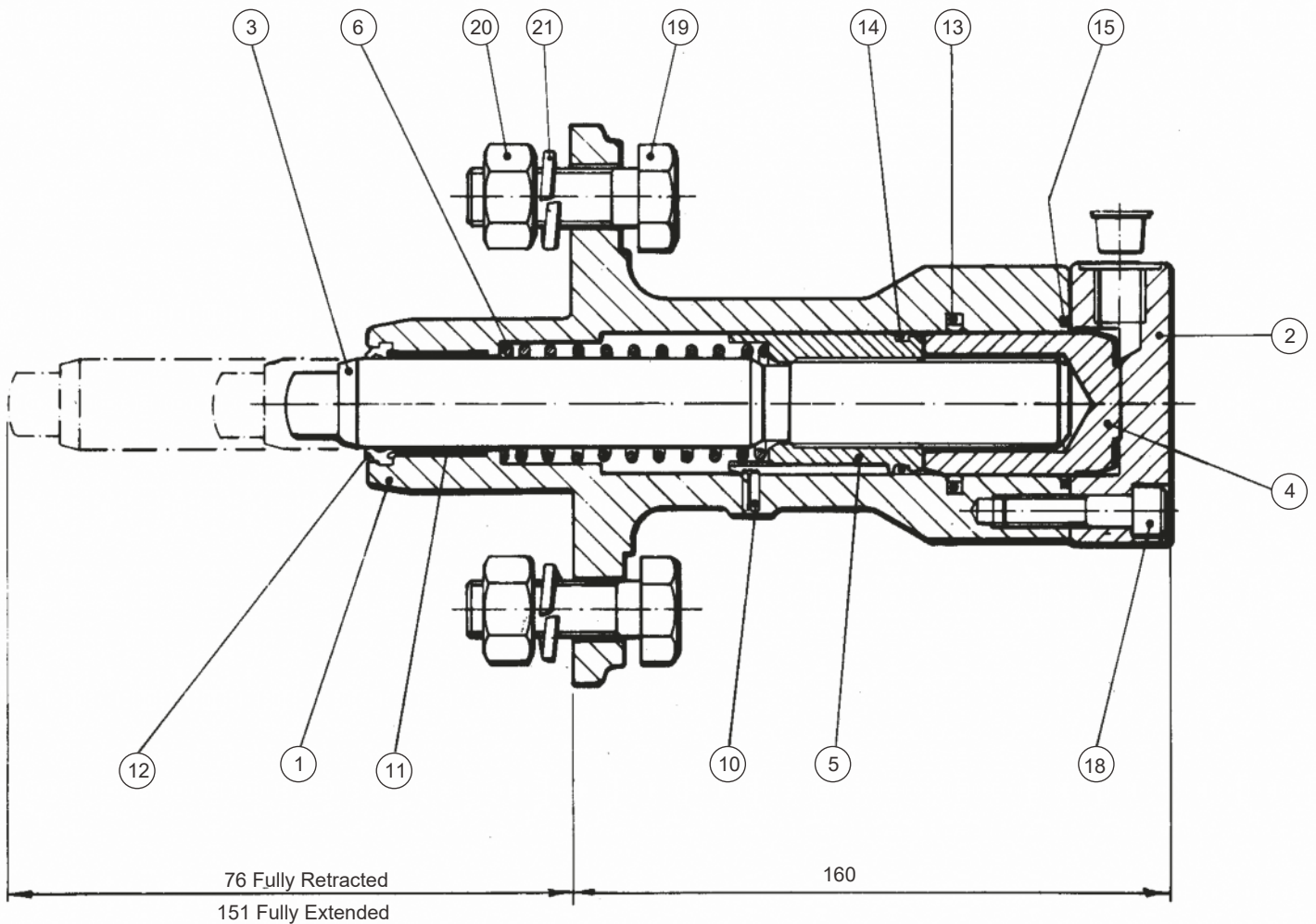

**Thruster Type - H**  
**Part No. 7500103**

**Maximum Displacement Volume 40ml.**  
**Weight of Thruster 2.9 kg.**

## Parts List

Item	Description	Part No.	QTY
1	Cylinder Body	-	1
2	End Cap	-	1
3	Pushrod	-	1
4	Piston	-	1
5	Sleeve	-	1
6	Compression Spring	-	1
7	-	-	-
8	-	-	-
9	-	-	-
10	Roll Pin	-	1
11	Bush	1800372	1

Item	Description	Part No.	QTY
12	Wiper Seal	6000242	1
13	Piston Seal	6000202	1
14	O' Ring	6000253	1
15	O' Ring	6000198	1
16	-	-	-
17	-	-	-
18	M8 x 35 Skt hd Cap Screw	-	4
19	M16 x 45 Hex. Bolt	-	2
20	M16 Nut	-	2
21	M16 Spring Washer	-	2

# GMR-H and GMR40-H Disc Brake Caliper - Hydraulically Applied, Spring Released

The GMR-H and the GMR40-H calipers are hydraulically applied and spring released. The braking force can be varied between zero and 36kN maximum by changing the applied oil pressure (see Brake Performance Chart.)

## Installation, Operation and Maintenance

### 1. Installation

- 1.1 The caliper must be mounted on a suitably rigid support, upon which braking forces of up to 36kN will be imposed.
- 1.2 The caliper should be positioned symmetrically with respect to the disc, as shown on the drawing.
- 1.3 Three fixing bolts are required, M16 grade 8.8. The bolts should be tightened to a torque of 150Nm.
- 1.4 If the caliper is to be mounted on an inclined surface, the caliper should be fitted with adjustable stop screw and bias springs, included in the inclined mounting kit (Part Number 6700458, drawing number A11362).
- 1.5 Calipers are normally supplied assembled 'right-handed', as shown on the drawing, unless otherwise specified.
- 1.6 The thruster is normally supplied separately from the caliper. Nuts, bolts and washers to fit the thruster to the caliper arm are supplied for this purpose and should be tightened to 45Nm torque.
- 1.7 The hydraulic inlet connection on the thruster is tapped G 1/4 (1/4" BSP). The hydraulic supply should be connected via a length of high pressure (175 bar) flexile hose to accommodate the movement during operation the volume of hydraulic fluid required for 20mm stroke is 23 ml. Mineral based hydraulic fluids such (such as Shell Tellus 37 or Catrol Hypsin AWS32) or mineral oil in water should be used.  
**IMPORTANT NOTE: Vegetable based fluids MUST NOT BE USED.**  
No special provision made for bleeding.

### 2. Operation

- 2.1 The brake is applied by the hydraulic pressure and retracted by the tension springs on the caliper and the internal return spring in the thruster. Variable braking torque can be achieved by regulating the oil pressure as shown on the charts. The braking force is proportional to the applied oil pressure. The normal maximum operating pressure is 140 bar, corresponding to a tangential braking force of 36kN (with standard pads).
- 2.2 THE THRUSTER STROKE SHOULD BE MAINTAINED AT ABOUT 20mm BY UNSCREWING THE PUSHROD. To adjust, the brake must be off (i.e. hydraulic pressure). Pull the caliper arm away from the pushrod and turn the rod as required; one turn gives 2mm adjustment. Release the caliper arm, ensuring that the flats on the push rod are engaged in the slot in the caliper arm. (A 17mm A/F spanner will fit the flats on the pushrod). N.B. Keep fingers clear of the space between pushrod and caliper arm at all times.
- 2.3 If an inclined mounting kit is fitted, the stop screw should be re-adjusted to maintain equal pad clearance on either side of the disc.
- 2.4 Pad wear can be monitored by observing the gap between the lugs on the pad pressure plates and the adjacent machined surfaces on the caliper frame, when the brake is applied. Pads must be replaced (see 3.2) before the gap is reduced to zero. (The maximum allowable wear on a pad is 10mm).

### 3. Maintenance

#### CALIPER

- 3.1 Ensure that the brake pad and disc remain free from oil and grease. Clean the disc as require. If the pads become contaminated they should be replaced. Carry out any periodic statutory testing that is required, or otherwise check for satisfactory performance.
- 3.2 Pad replacement is carried out from the rear of the caliper; DO NOT release the spring clips which attach the pressure plates to the caliper arms. With the brake off remove the caliper return springs and the keep plates. If an inclined mounting kit is fitted, remove this also. Withdraw the pads to the rear and lift out. (The hole in the end of the pad retaining plates is provided to assist in withdrawing the pads). Fit the new pads (part number 7080080), ensuring that the slotted retaining plate is located around the keep disc on the pressure plate; the pads should slide freely into position. Replace remaining parts. Re-adjust the push rod, as in (2.2), and the stop screw if fitted (as in 2.3).
- 3.3 The surface of the caliper arm on which the thruster pushrod bears should be kept well greased. The knuckle joints between the caliper arms and the pressure plates should be cleaned occasionally, and a small amount of grease applied; the joints may be levered apart slightly against the pressure of the spring clip. Occasionally, or if caliper is not operating freely, inject a small amount of grease via grease-nipples to lubricate the pivot pins, then rotate pins to distribute the grease. Any grease exuding past the O-rings should be wiped off. The pins may be turned by gripping the knurled end at the top of the caliper.

After extended {one million operations or three years) use, the pivot pins should be withdrawn, cleaned, replaced and re-greased, or replaced if badly worn.

In order not to damage the O-ring seals on the pins, use the following procedure. Remove the top circlip, push pin down until the lower circlip and O-ring can be removed, then withdraw the pin upwards. To refit, reverse this procedure.

## THRUSTER

- 3.4 Clean the push rod as required, and inspect hydraulic connections and hoses.
- 3.5 In the event of leakage or malfunction of the thruster, the following parts can be inspected and replaced if necessary, using the procedures described below:
- Pushrod (3)
  - Sleeve (5)
  - Bush (11)
  - Wiper Seal (12)
  - Piston Seal (13)
  - O-Rings (14, 15)

## Thruster Servicing

- 3.6 Disconnect the hydraulic supply and remove thruster from caliper. Gently unscrew the four cap screws (18) and remove the end cap (2). The piston (4) may be extracted from the cylinder body (1) by pressing on the protruding end of the pushrod (3). The pushrod (3), sleeve (5) and spring (6) may all be removed by further movement through the cylinder.

Clean and examine all parts. The surface of the pushrod should be smooth and free from serious souring or bruising. If the pushrod is known to be damaged, replace it.

Leakages of fluid past the piston seal or the end cap may be caused by damage to the seals, or to the seal grooves in the piston.

- 3.7 The wiper seal (12) serves both to retain grease and to exclude dirt. The section of the pushrod which moves through the wiper seal should be cleaned with a very slight lubricant film. The wiper seal is of all rubber construction and is easily replaced without tools.
- 3.8 The bush (11), which is pressed into the front cap, has a number of shallow circular indentations in its surface, which retain grease. The limit of acceptable wear on the bush is 0.2mm, approximately half the depth of the indentations in a new bush.
- A worn bush can be withdrawn (after removal of the wiper seal which may be re-used unless damaged) using a suitable extractor. The new bush, should be pressed in until flush with the base of the wiper seal recess.
- 3.9 The piston seal (13) which has two parts, (a P.T.F.E. sealing ring and an O-ring) may be removed using a small screwdriver or similar tool. Take care not to damage the groove. Once removed the seal should not be re-used.
- When fitting a new piston seal, the P.T.F.E. ring must be carefully deformed without sharp bends to allow insertion into the internal groove, then expanded into a circle again. The piston can be used as a tool for reshaping the ring.
- 3.10 Re-assembly of the thruster is the reverse of dismantling. The pushrod thread, the bush and the sleeve should be lightly greased to ease assembly and the piston oiled with hydraulic fluid.

The sleeve (5) should be screwed on to the pushrod until it bottoms on the pushrod shoulder, then the pushrod assembly and compression spring inserted into the cylinder followed by the piston. The end cap may be located on the piston and the securing screws (18) engaged in the cylinder but not tightened. The anti-rotation roll pin (10) acts as a stop unless the pin and sleeve slot are in line. Therefore the pushrod should be rotated by a spanner applied to the flats at the same time as gentle pressure is applied end cap (2). When the anti-rotation pin (10) is engaged in the slot, the end cap screws (18) should be tightened to a torque of 30Nm. Refit the thruster to the caliper, and adjust pushrod stroke. Check for leaks and correct operation.

## 4. Recommended Lubricants

- 4.1 Caliper: Medium grease containing Molybdenum disulphide.
  - e.g. Castrol LMM
  - Shell Alvania 2 + MoS<sub>2</sub>
- 4.2 Thruster: Medium lithium based grease with rust inhibitors
  - e.g. Duckham's Keenomax L2
  - Castrol AP 2
  - Shell Alvania R2

## 5. Spares

- 5.1 A spare set of brake pads, a diaphragm and a set of seals should be kept in a cool, dry, dark place where there is no chance of contamination.
- 5.2 For caliper spares see Data Sheet DB 3604.

## 6. Service

Address all enquiries regarding this equipment to Howdon Power Transmission Ltd



This approval is in Accordance with  
Certificate number 850822  
Issue 04 June 2009 © Twiflex 2001 Issue 05

Tel: +44 (0)1453 750814  
Fax: +44 (0)1453 765320  
[www.howdon.co.uk](http://www.howdon.co.uk)  
[sales@howdon.co.uk](mailto:sales@howdon.co.uk)