

MSH Disc Brake Caliper - Mechanically Applied, Hand Operated

Nominal dimensions given
For caliper dimensions see DS1500

DS1506

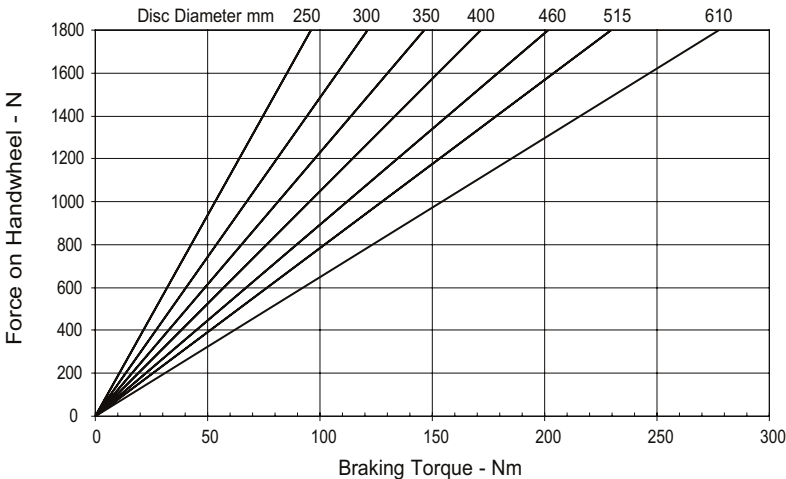
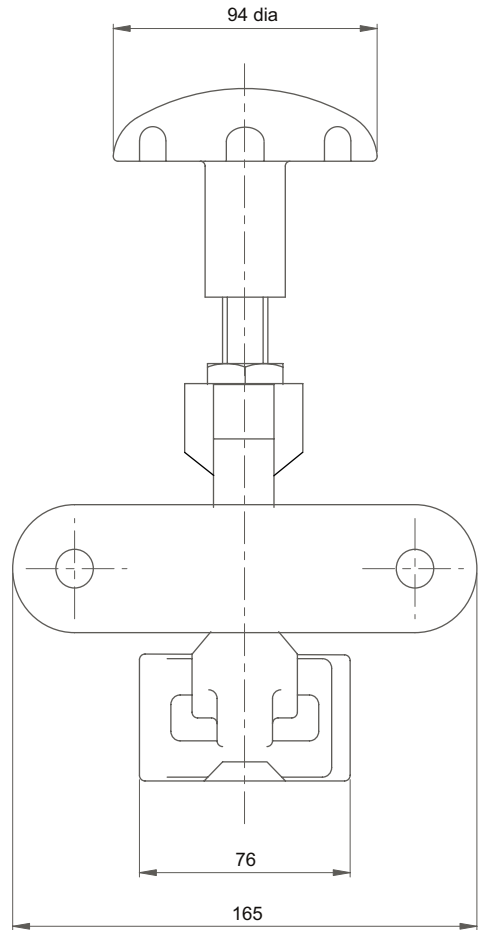
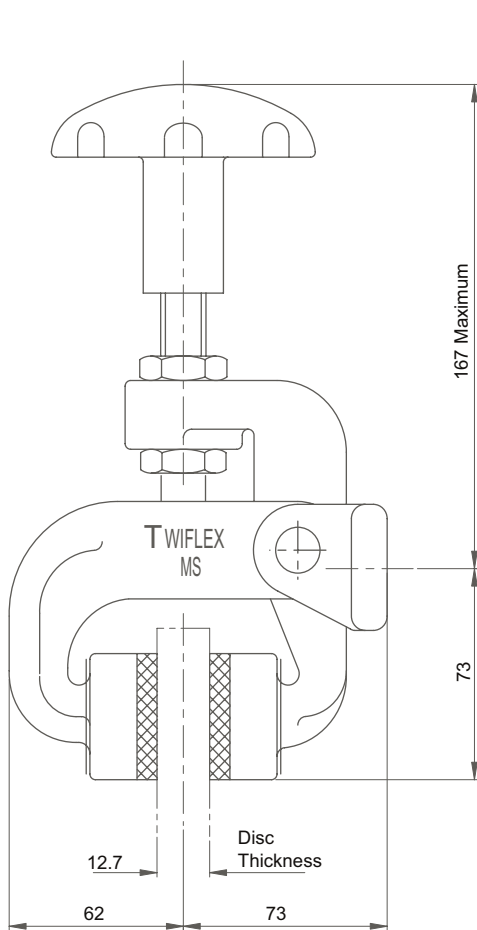

Weight (Caliper and Hand knob) - 2.53kg
(Hand knob only) - 1.03kg

Maximum Braking Force = 1.01kN
1 Turn of Hand knob = 90N braking force

The ratings shown on the above graph are based on fully bedded and conditioned brake pads with nominal friction coefficient $\mu = 0.4$.

For bedding-in and conditioning procedures see Publication M1060.

Braking Force is defined as the Tangential Force acting on the brake disc at the Effective Disc Radius.

Braking Torque (Nm) = Braking Force (N) x Effective Disc Radius (m) where Effective Disc Radius = Actual Disc Radius - 0.03.

Twiflex Disc Brakes must be used with Twiflex asbestos free brake pads. The use of any other brake pads will invalidate the warranty.

Twiflex Limited reserves the right to modify or change the design without prior notice.

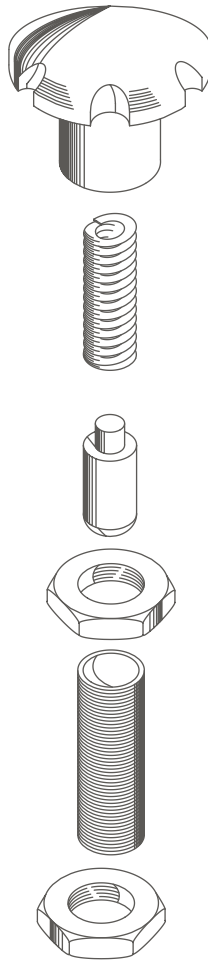

Hand knob assembly part number 7800127

Hand knob assembly fitment

1. Offer hand knob assembly to caliper making sure that one lock nut is removed before placing push rod through caliper arm.
2. Fit a lock nut over the push rod, locate the push rod within the slot of the opposite arm.
3. Adjust the lock nuts until the push rod contacts the opposite arm
4. Tighten the lock nuts to 50-60 Nm.

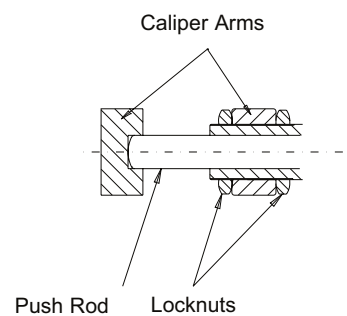

Twiflex Limited.

The Green Twickenham
TW2 5AQ England

Tel: 020 8894 1161
Fax: 020 8894 6056
Website: www.twiflex.com
e-mail: sales@twiflex.co.uk